

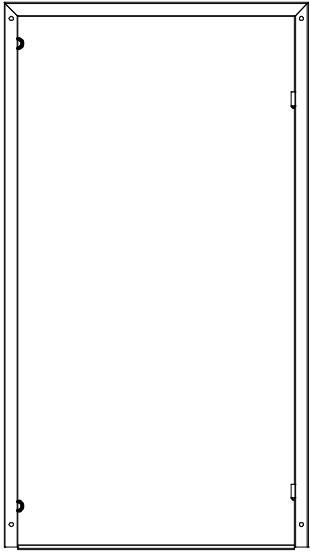

SPOJOVACÍ PŘÍČKA 4x C



PŘEDNÍ RÁM
1x A



ZADNÍ RÁM
1x B

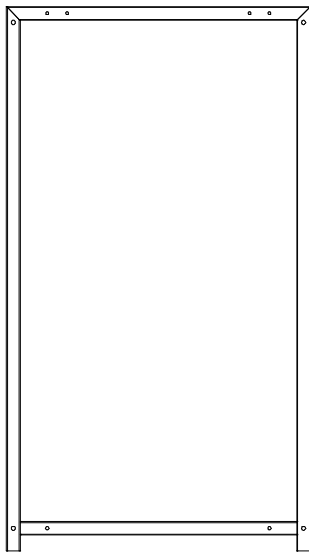

ZÁSLEPKA
4x B1

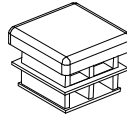

VÍKO
1x D

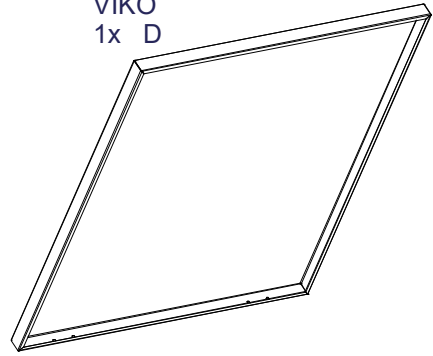

výztuha VÍKA PRAVÁ
1x D1

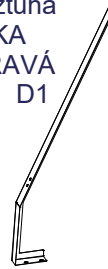

výztuha VÍKA LEVÁ
1x D2

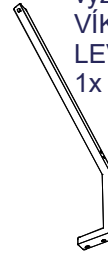

ŘETÍZEK
2x D3



ZADNÍ PLECH
1x F

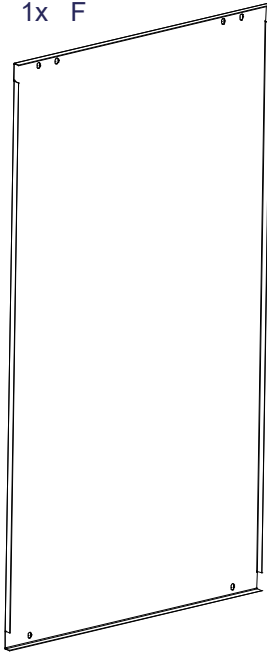

DVEŘE
1x G

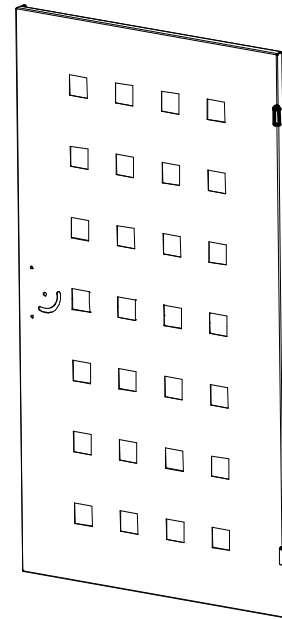

ČEP PANTU
2x G1



Šroub M5x16
2x D4



Podložka 6
5x D5



Samojistná Matice M5
2x D6



MADLO
2x H

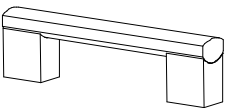

Šroub M6x16
1x J

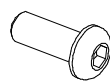

Šroub M6x40
2x K

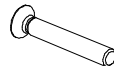

Šroub M6x70
3x K1

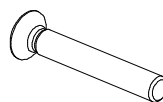

Šroub M6x80
1x K2

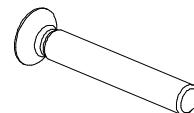

Samojistná Matice M6 7x L

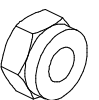

Šroub M4x12
4x H1

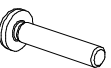

Podložka 5
2x H2



Šroub M4x10
4x N2



Samojistná Matice M4
8x N3



ZAJIŠTĚNÍ DVEŘÍ
1x O

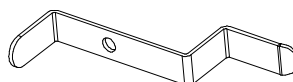

Šroub M8x50
8x M

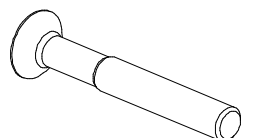

PANT
2x N

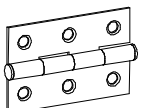

Šroub M4x40
4x N1

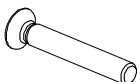

1.

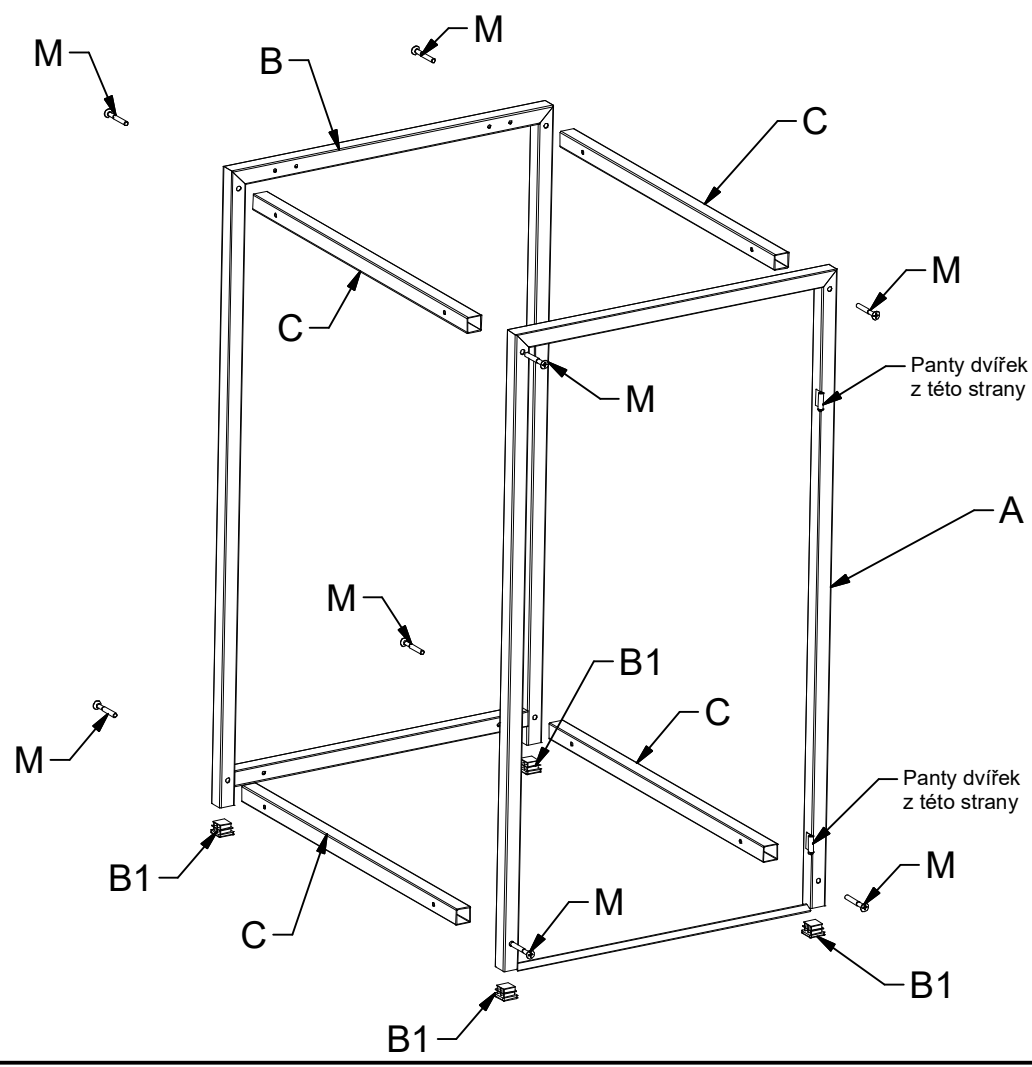

2.

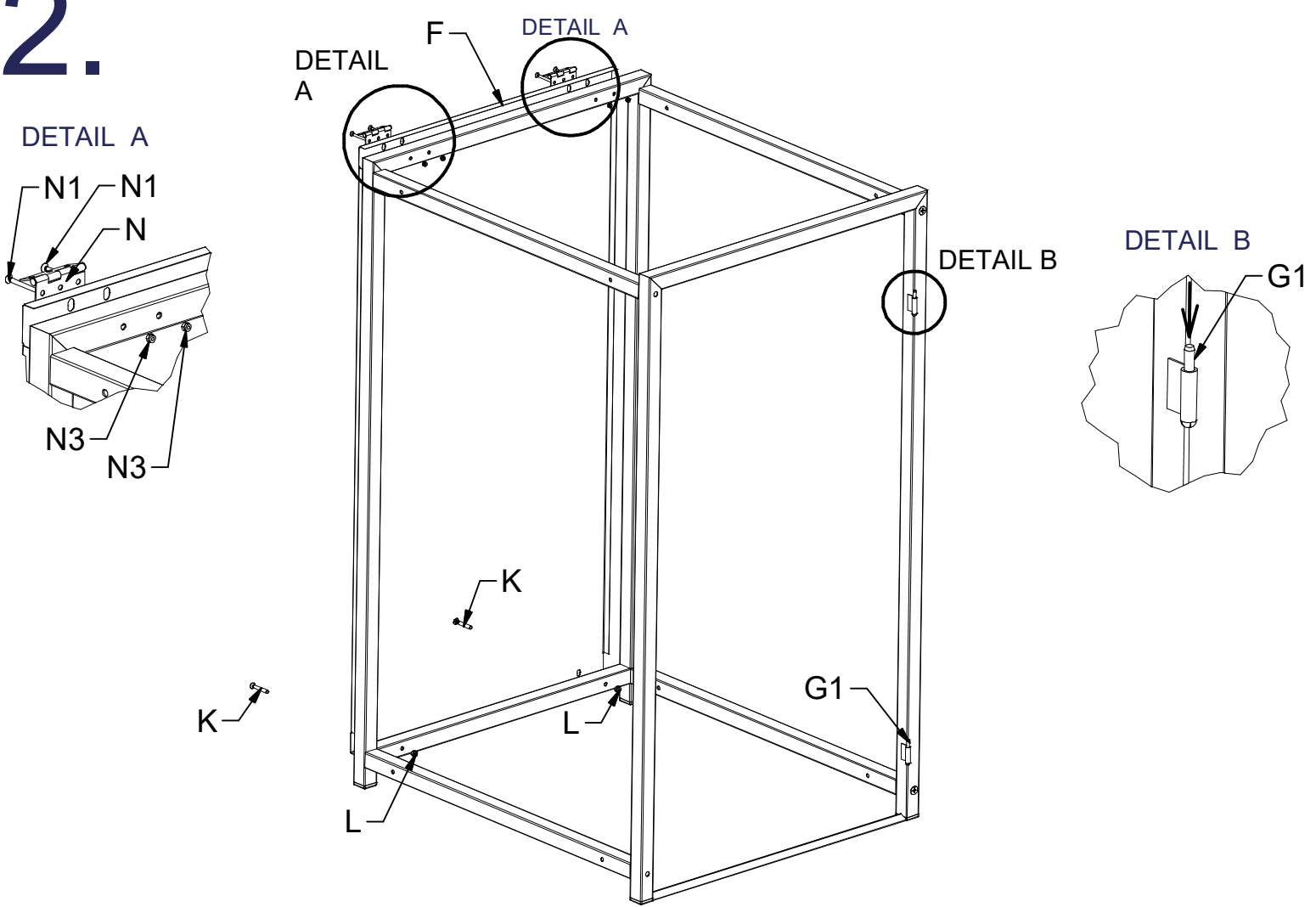

3.

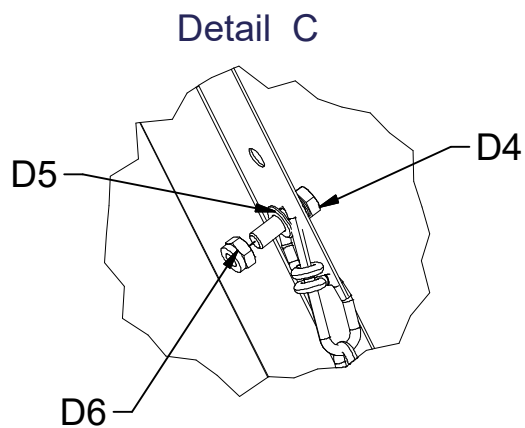
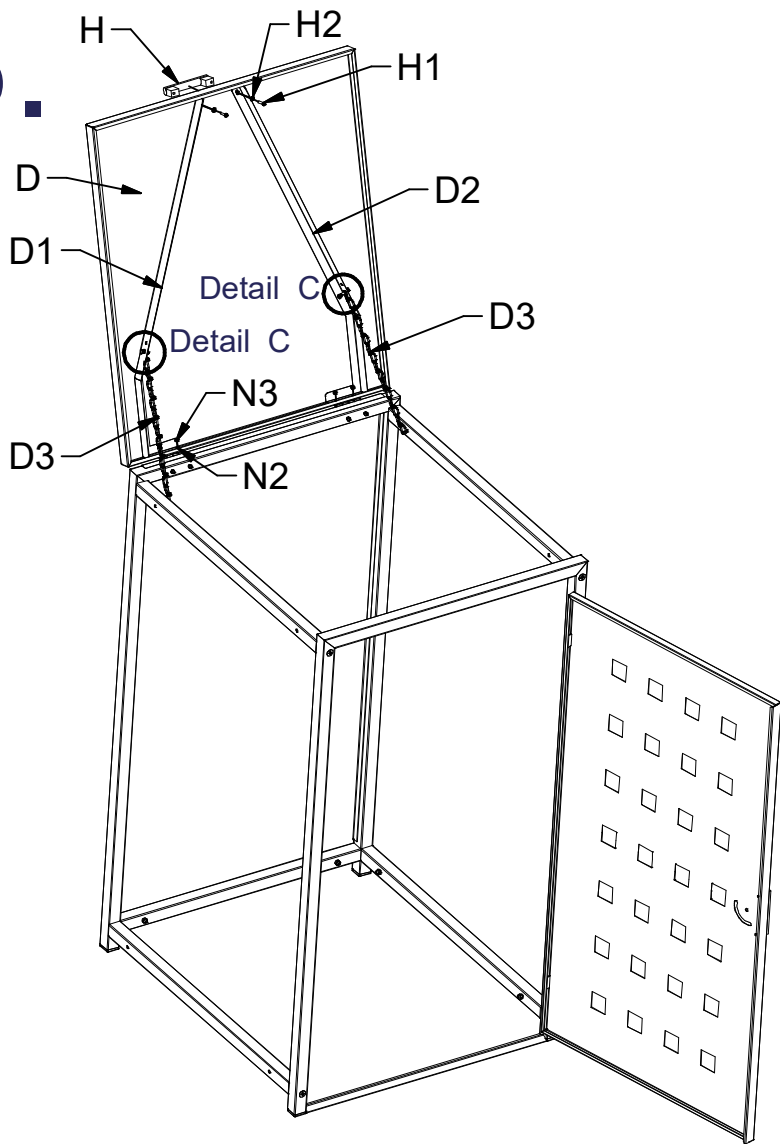

4.

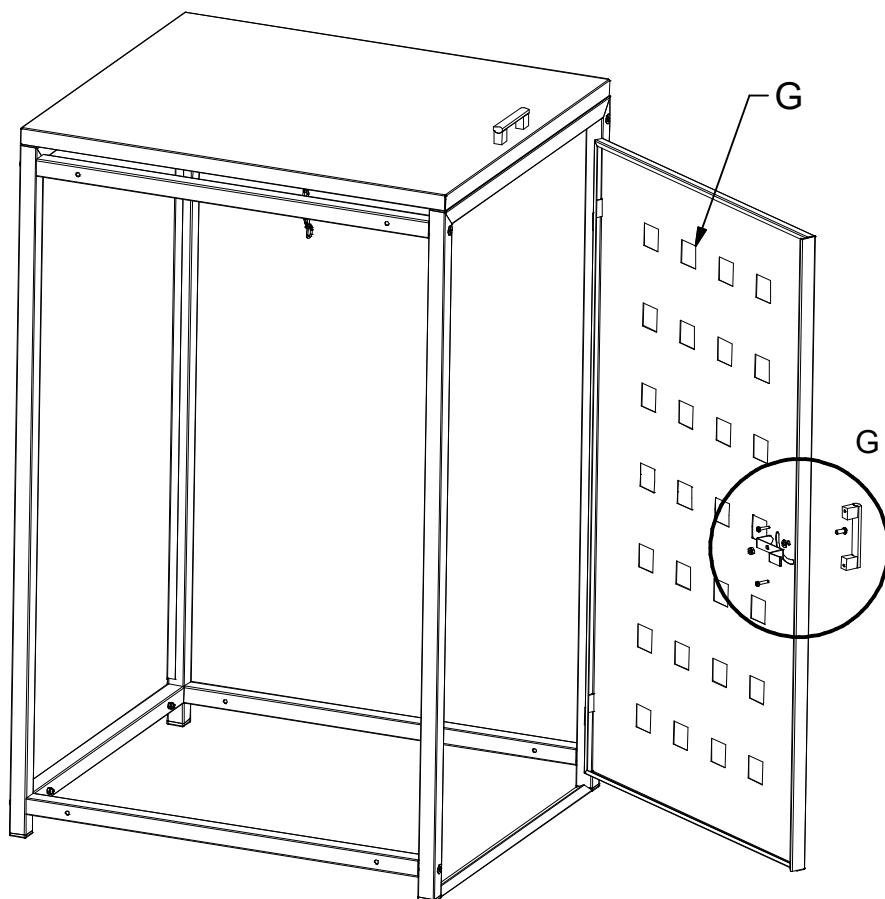
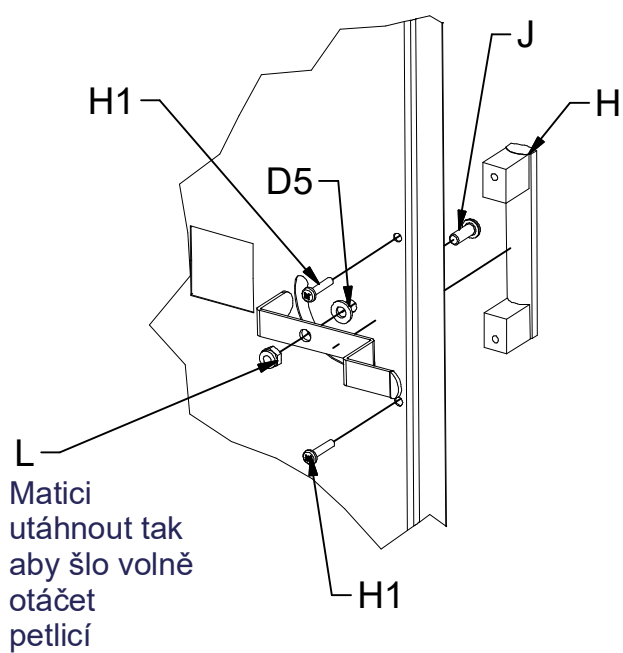

5.

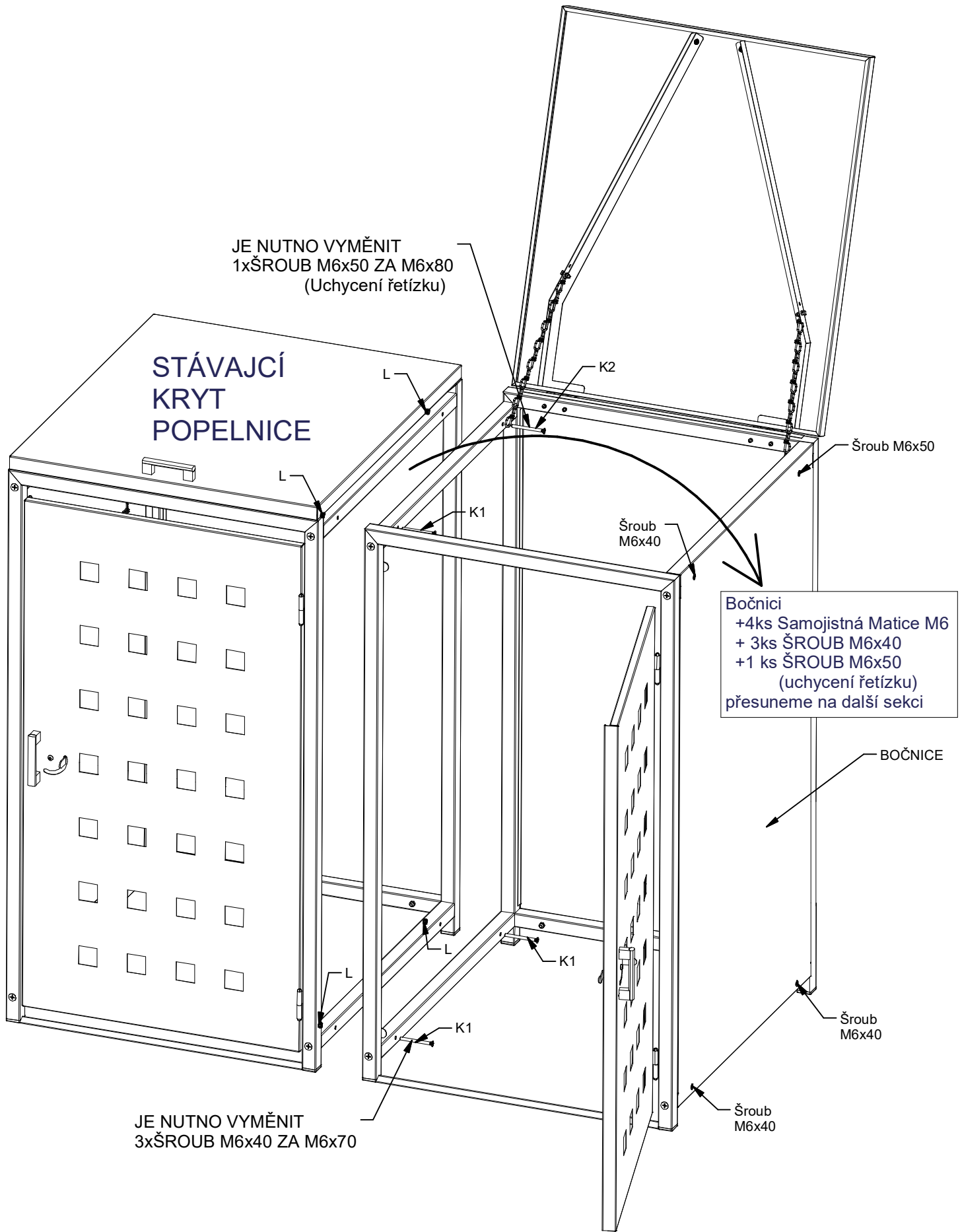

JE NUTNO VYMĚNIT
1xŠROUB M6x50 ZA M6x80
(Uchycení řetízku)

STÁVAJÍCÍ
KRYT
POPELNICE

Bočnice
+4ks Samojistná Matice M6
+ 3ks ŠROUB M6x40
+ 1 ks ŠROUB M6x50
(uchycení řetízku)
přesuneme na další sekci

JE NUTNO VYMĚNIT
3xŠROUB M6x40 ZA M6x70

BOČNICE

Šroub
M6x40

Šroub
M6x40

Šroub M6x50

Šroub
M6x40