

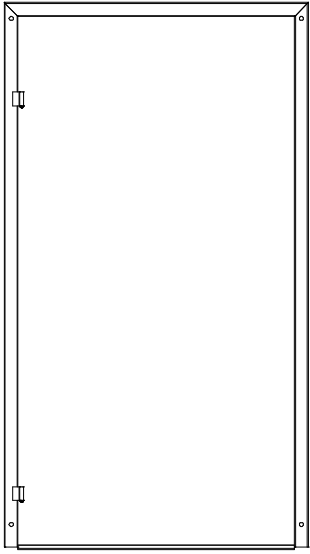

SPOJOVACÍ PŘÍČKA 4x C



PŘEDNÍ RÁM
1x A



ZADNÍ RÁM
1x B

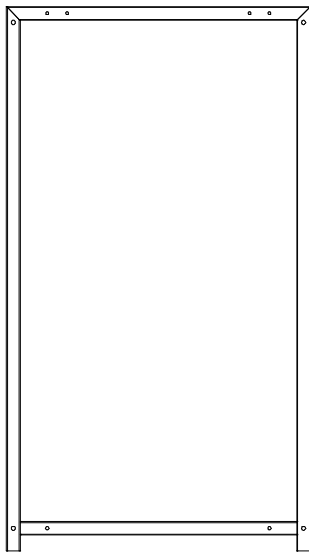

ZÁSLEPKA
4x B1

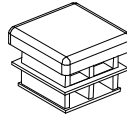

VÍKO
1x D

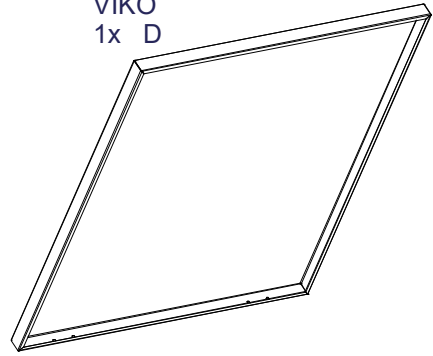

výztuha VÍKA PRAVÁ
1x D1

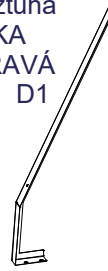

výztuha VÍKA LEVÁ
1x D2

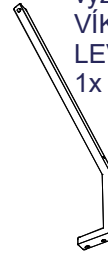

ŘETÍZEK
1x D3



BOČNÍ PLECH
2x E

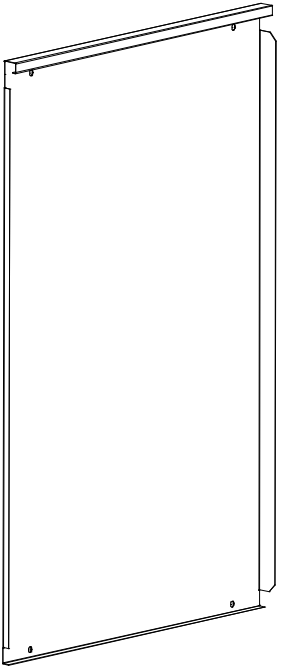

ZADNÍ PLECH
1x F

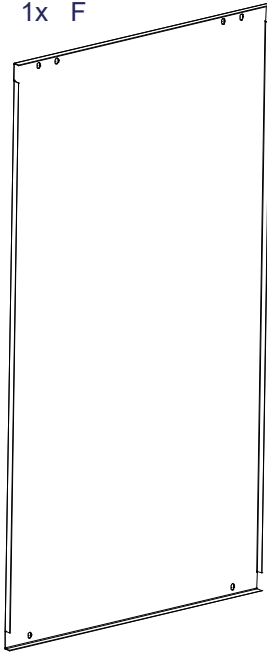

DVEŘE
1x G

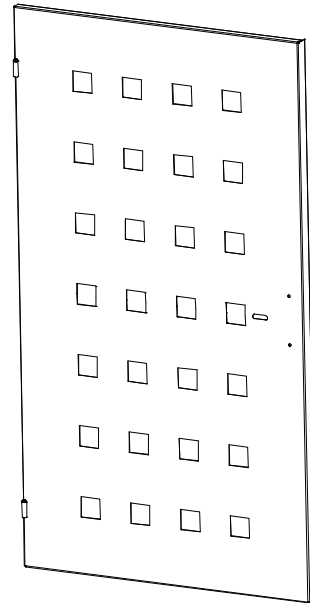

ČEP PANTU
2x G1



Šroub M5x16
1x D4



Podložka 6
2x D5



Samojistná Matice M5
1x D6



MADLO
2x H

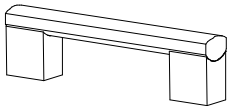

DORAZ DVEŘÍ
1x J



Šroub M6x40
9x K

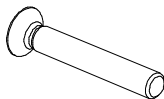

Šroub M6x50
1x K1

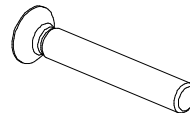

Samojistná Matice M6 10x L

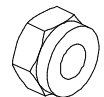

Šroub M4x12
4x H1

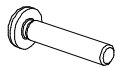

Podložka 5
2x H2



Šroub M4x10
4x N2



ZAJIŠTĚNÍ DVEŘÍ
1x O

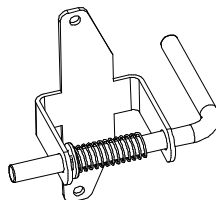

Šroub M8x50
8x M

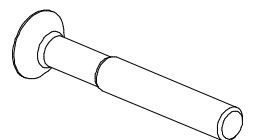

PANT
2x N

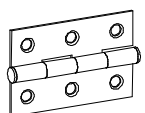

Šroub M4x40
4x N1

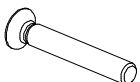

Samojistná Matice M4
8x N3



1.

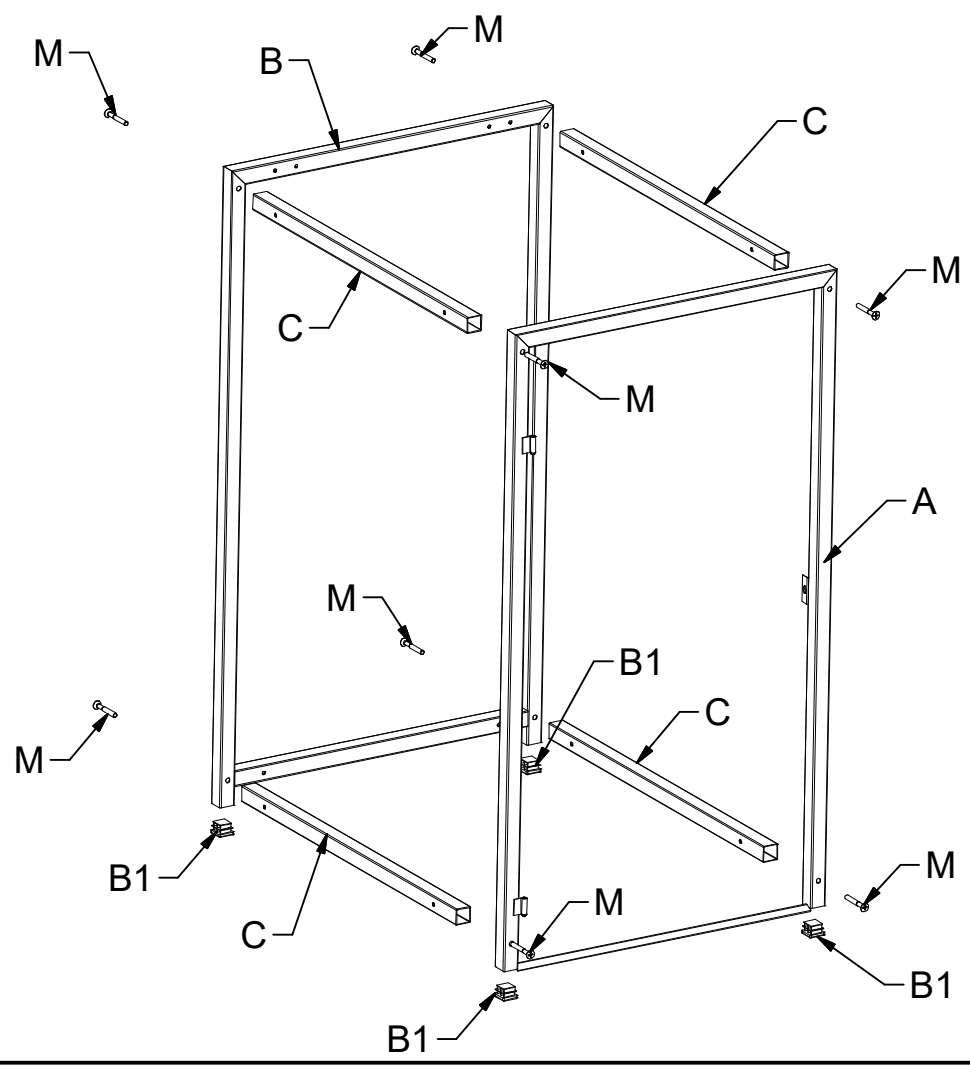

2.

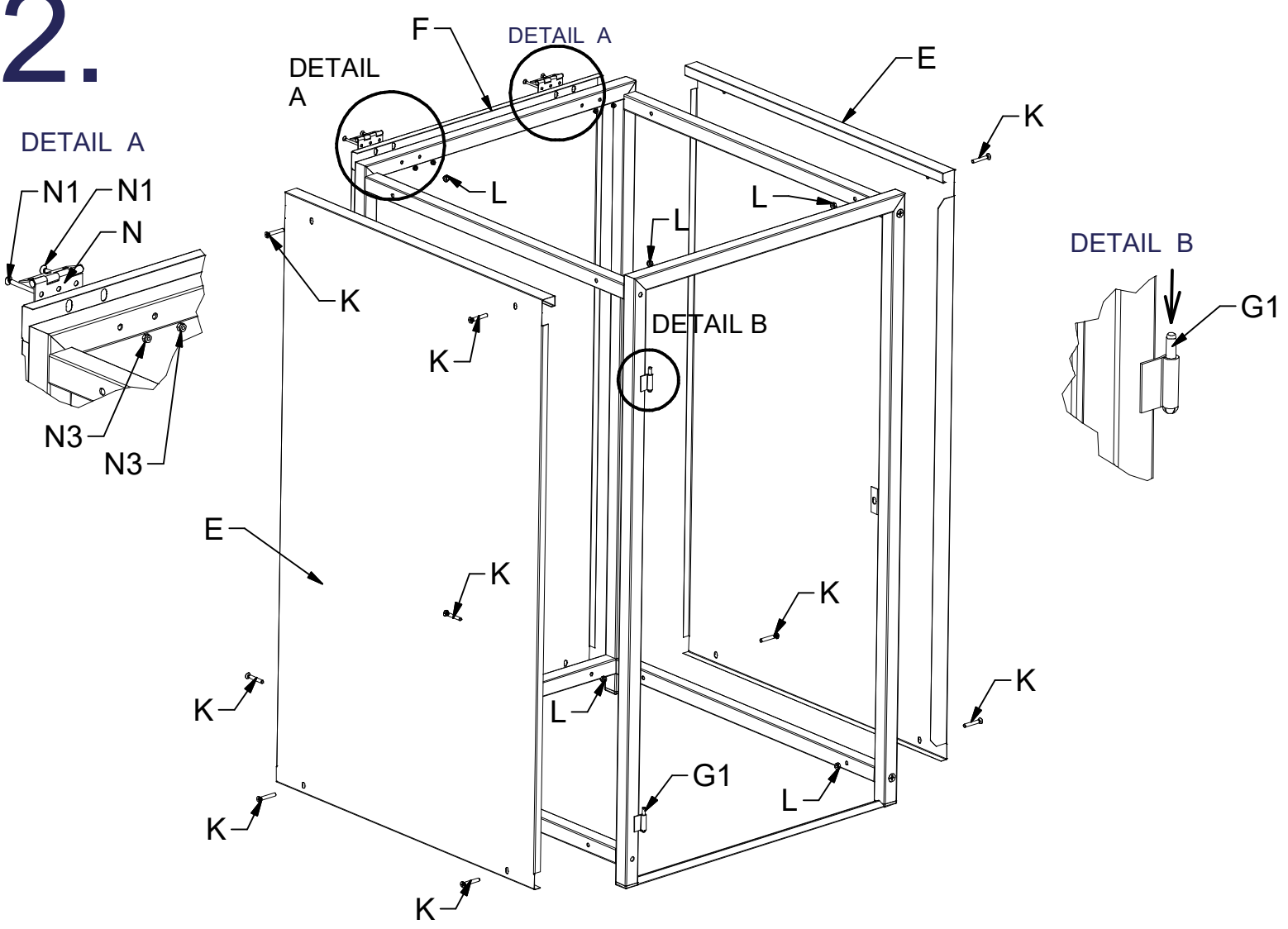

3.

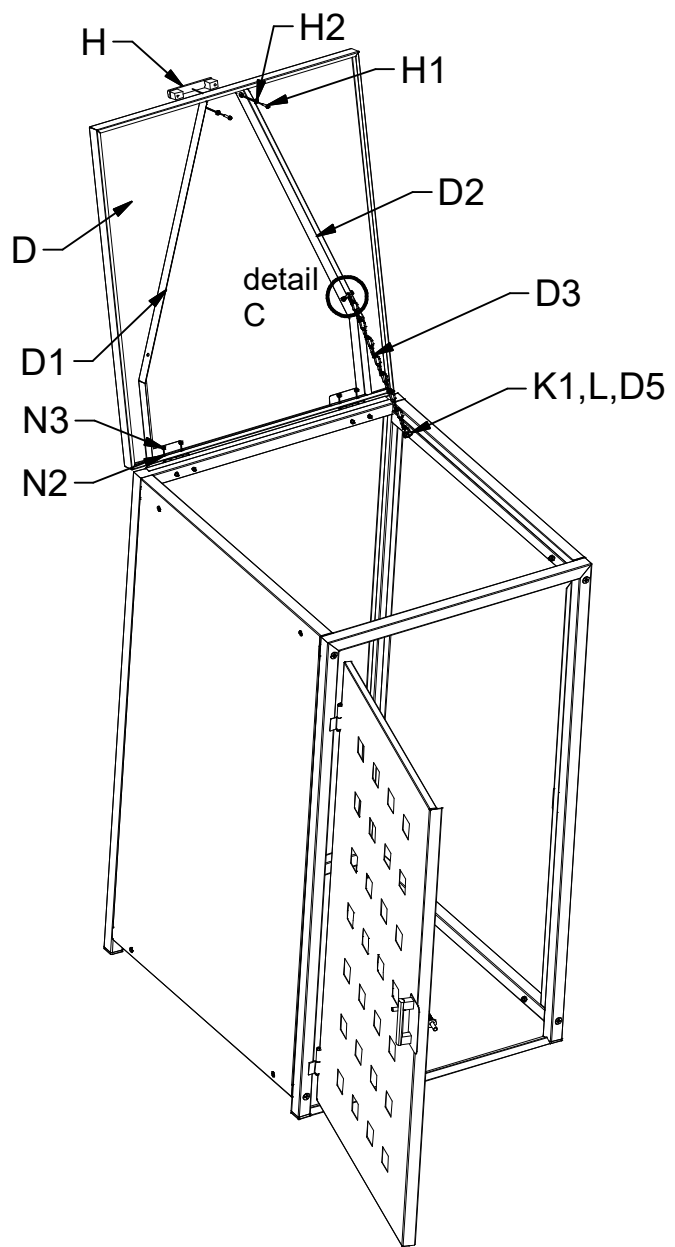

Detail C

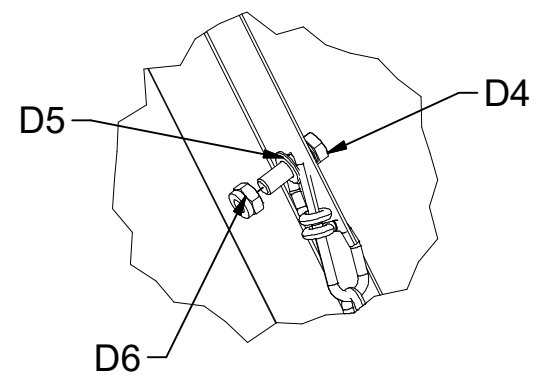

4.

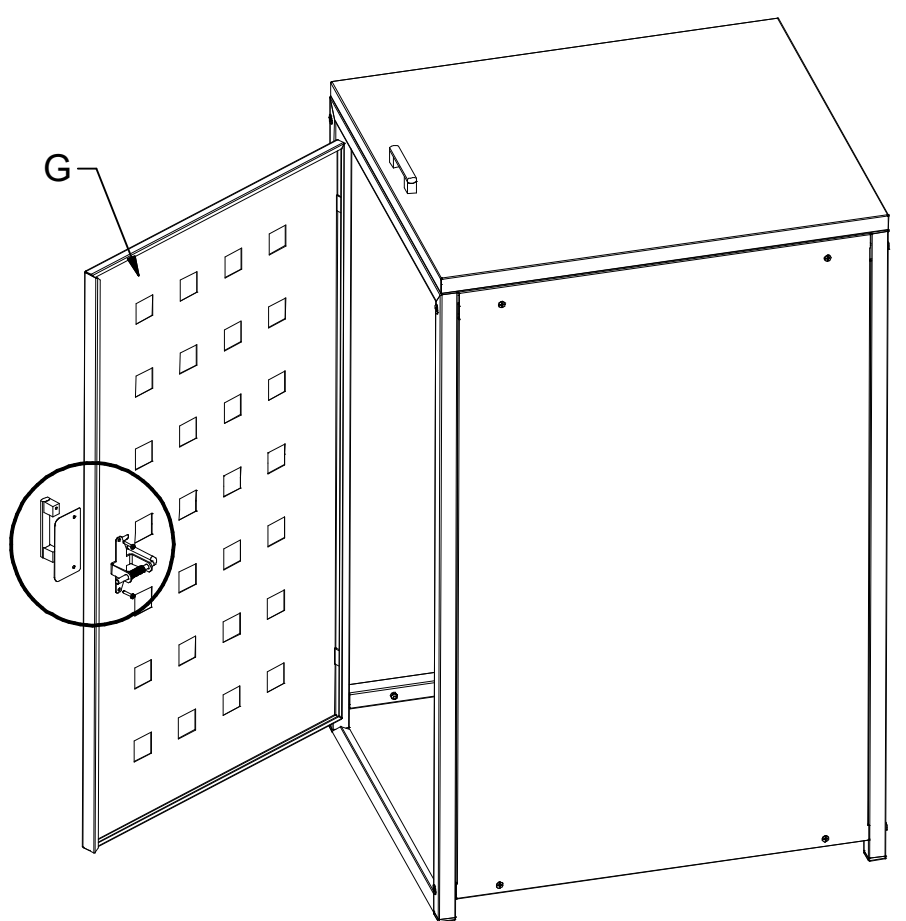
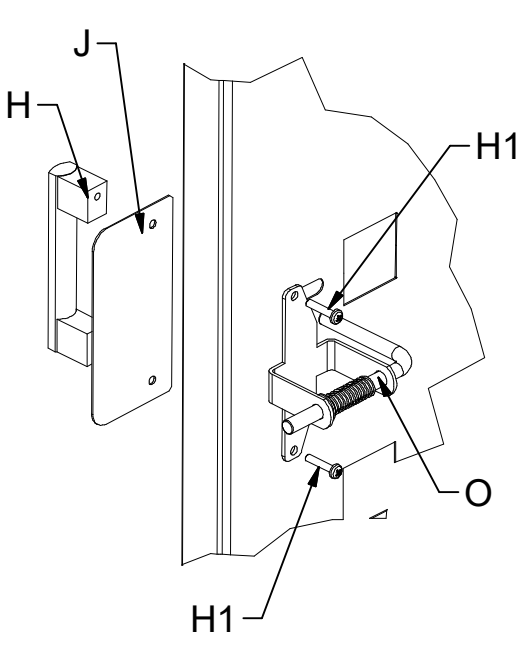

5. SAMOSTATNĚ STOJÍCÍ KRYT POPELNIC

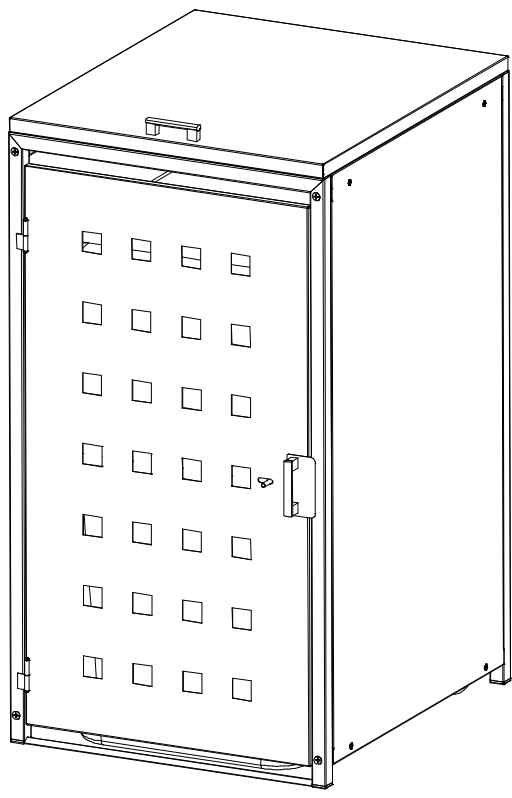

MONTÁŽ DALŠÍ SEKCE KRYTU POPELNIC

