

- Před montáží si přečtete celý návod
- Pomocí seznamu dílů se přesvědčte, že jste obdrželi všechny jeho části
- Při montáži používejte vhodné bezpečnostní brýle nebo jiné ochranné pomůcky

Před montáží

Před instalací si důkladně prostudujte tyto pokyny. Během instalace je třeba dodržovat místní bezpečnostní předpisy a průmyslové normy. Nařízení se mohou, mimo jiné, vztahovat na:

- Bezpečnostní přilby, ochranu očí a ochranný oděv
- Bezpečnostní postroj pro pracovníky pracující ve výškách
- Řádný žebřík, klec a jejich bezpečné použití

Před instalací zkontrolujte všechny součásti a díly. Všechny díly jsou označené číslem, při kontrole tato čísla porovnejte s dodaným seznamem dílů.

Pro instalaci si zvolte bezvětřný den nebo den s mírným větrem. Pokud fouká silný vítr, je montáž náročná. Konstrukci nijak neupravujte. Během instalace na rám nezavěšujte žádná závaží, ani díly. Neručíme za škody nebo zranění vzniklá nesprávnou instalací, neoprávněnými úpravami nebo extrémním počasím. Tato stavba není určena pro bydlení.

Na rám, kde se spoje dotýkají a kde se rám dotýká krytu, doporučujeme nalepit nebo přidat pěnu/gumu. Prodlouží to životnost krytu.

Před sestavením si nejprve pročtěte seznam částí a spočítejte položky, abyste věděli, že máte vše připravené.

Hlavní specifikace

Celková velikost po smontování (cm): D 257 * Š 192 * V 195 (cm)

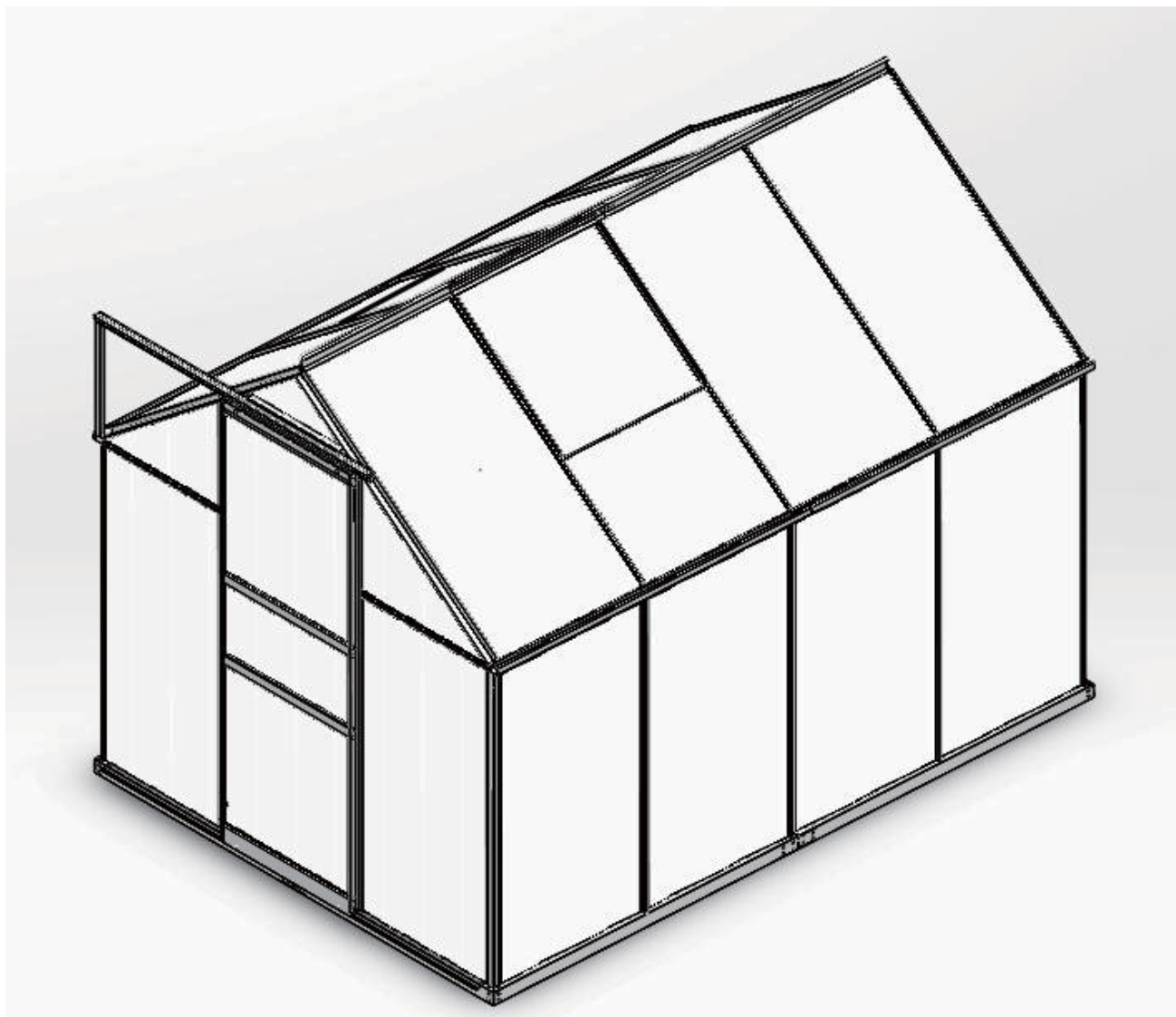

Doporučované nástroje

Ochranné pomůcky:

1. Bezpečnostní přilba



2. Rukavice



3. Ochranné brýle



Měřicí nástroje a instalační zařízení:

1. Měřicí pásmo



2. Úhelník



3. Štafle



4. Klíč C10



5. Křížový šroubovák















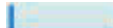



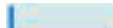









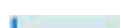









6. Značkovač













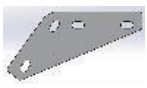

7. Palička

HLINÍKOVÉ SOUČÁSTI

MODEL – MODEL CODE – KÓD LENGTH – DÉLKA QTY - MNOŽSTVÍ

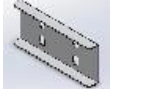
MODEL	CODE	LENGTH (mm)	QTY	MODEL	CODE	LENGTH (mm)	QTY	MODEL	CODE	LENGTH (mm)	QTY	MODEL	CODE	LENGTH (mm)	QTY
	C1301A	1551	1		C501	1150	4		C101A	1606	1		C2004	616	2
	C1301B	1551	1		C201	1150	6		C101B	1606	1		C2005	635	1
	C1801	590	1		C2501	1328.5	2		C203A	1622	1		C2201	621	2
	C701	600	1		C2502	1197.7	2		C203B	1622	1		C2202	610	3
	C1101	600	2		C2001	1310	4		C1901	644	2				
	C2301	600	1		C2101	1193.7	1		C202	1137	6				
	C2401	607	2		C2102	1280.5	1		C1001	405.5	1				
	C2601	602	2		C502A	1157	1		C401	606	1				
	C2701	600	4		C502B	1157	1		C601	1275	1				
	C801	971.3	1		C502C	1157	1		C2002	1253	4				
	C802	815.9	1		C502D	1157	1		C2003	610	2				



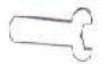



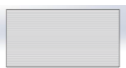
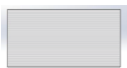

SEZNAM DALŠÍ DÍLŮ

MODEL	CODE	LENGTH (mm)	QTY	MODEL	CODE	LENGTH (mm)	QTY
	CBJ01	948.8	1		CBJ07	138*69	4
	CBJ03	948.8	1		CBJ08	185	1
	CBJ05	948.8	1		CBJ09	150*44	3
	CBJ06	948.8	1		CBJ10	30*40	4
	CBJ02	1289.6	2		CBJ11	100*44	1
	CBJ04	1249.6	2		CBJ12	100*22	3
	CBJ14	50*30	4		CBJ13	100*35	2
							2

MODEL – MODEL CODE – KÓD
 LENGTH – DÉLKA QTY - MNOŽSTVÍ

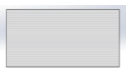
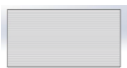
MODEL	CODE	LENGTH (mm)	QTY
	C1	28	1
	C2		4
	C4		165
	D1	M6X9*3.5	182
	C5		2
	C3		3
	D2	M6X16	2
	D3	M6X40	2
	D4	M4X10	5
	D5	ST4. 2X9.5	10
	D6	ST4. 8X19	18
	D7	M6-GB41	184
	D8	M10*100	4

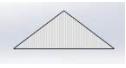
SEZNAM DESEK

MODEL	CODE	LENGTH (mm)	QTY	MODEL	CODE	LENGTH (mm)	QTY
	K001	562*598	2		A001	1148*617	8
	K002	261*598	1		A003	1150*617	6
	M001	628*604	2		A002	534*617	2
	E003	1146*621	2		D003	1146*610	3
	E002	454*621	2		D001	470*610	2
	E001	240*650	1		D002	698*610	1

MODEL – MODEL CODE – KÓD

LENGTH – DÉLKA QTY - MNOŽSTVÍ

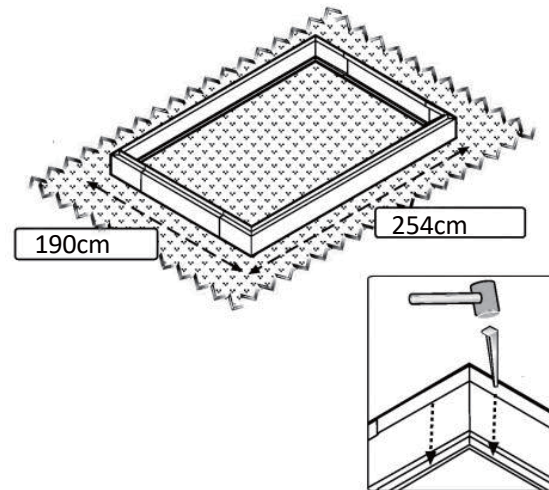
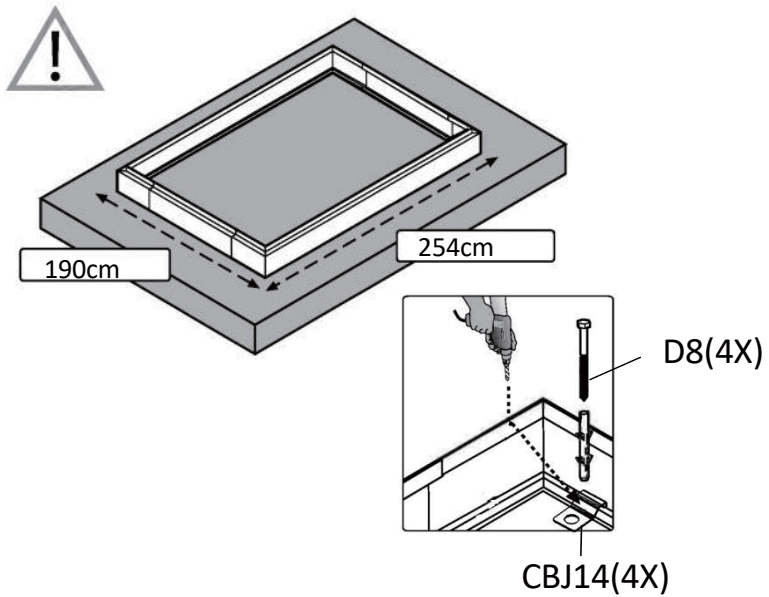
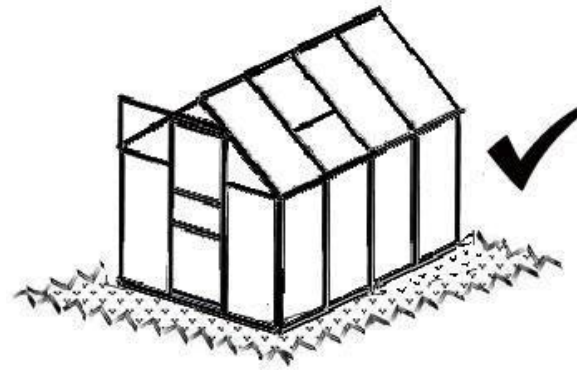
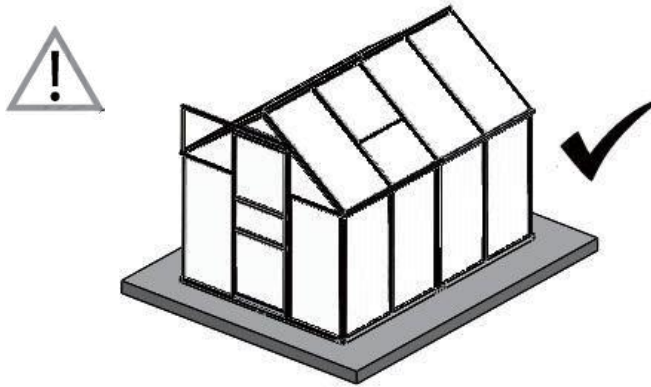



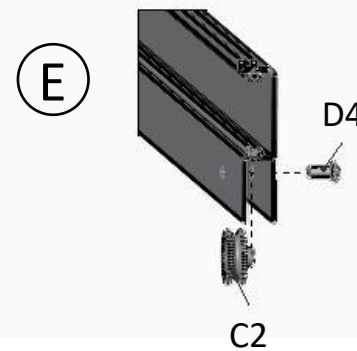
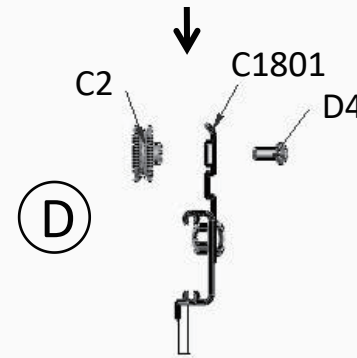
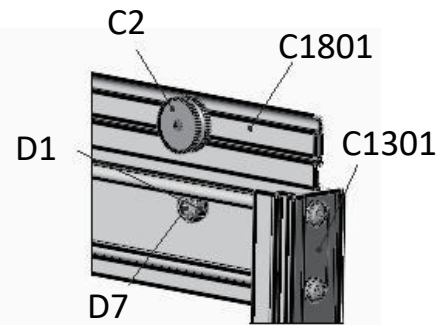
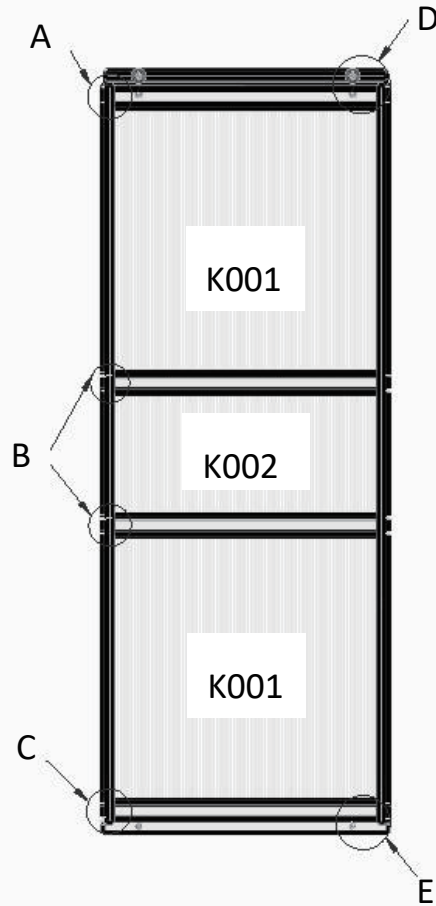
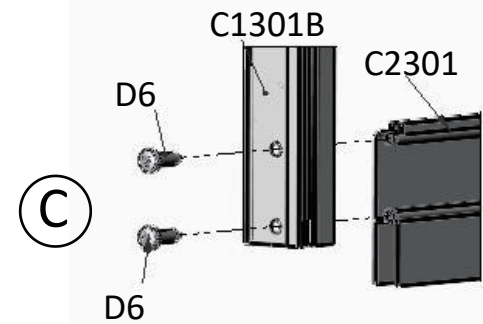
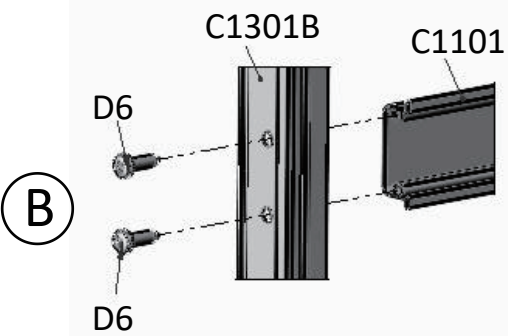
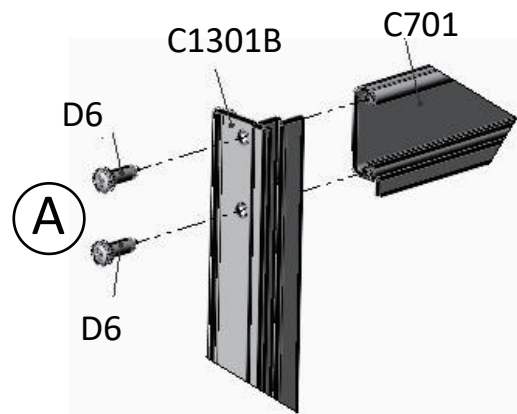



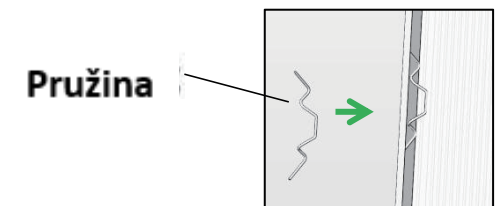

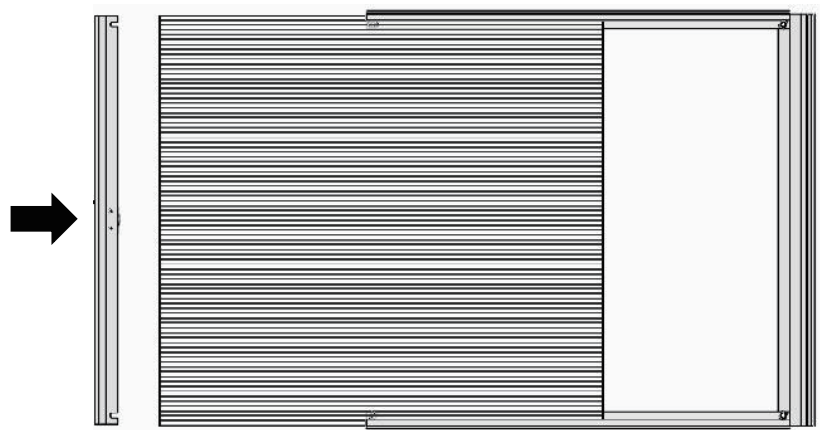
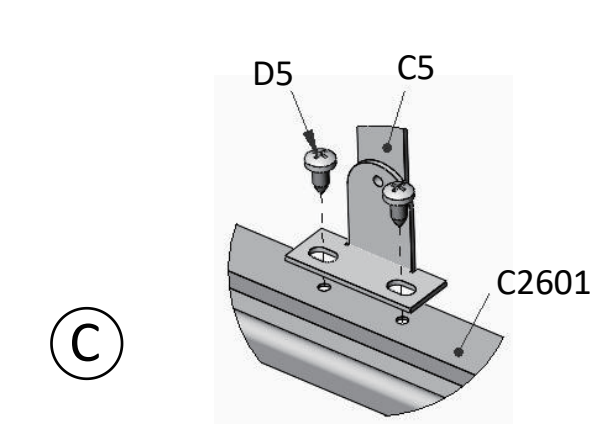
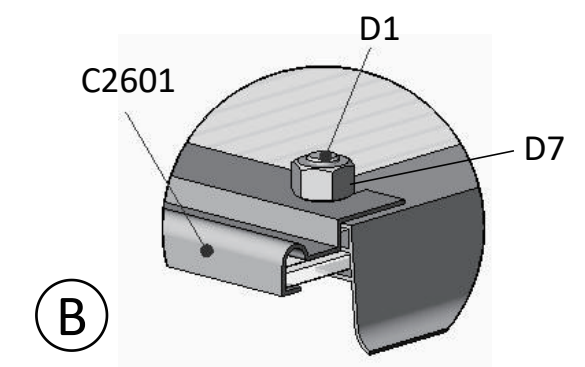
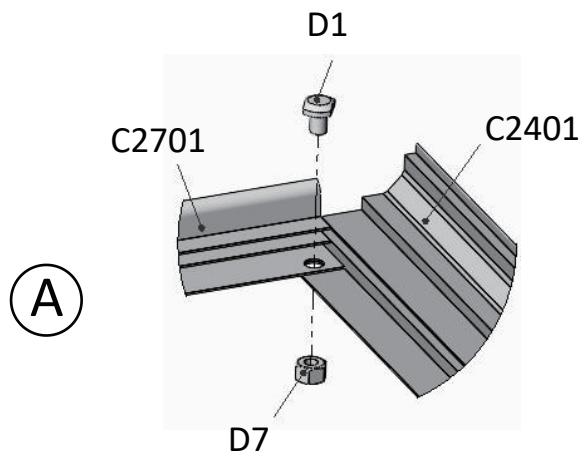
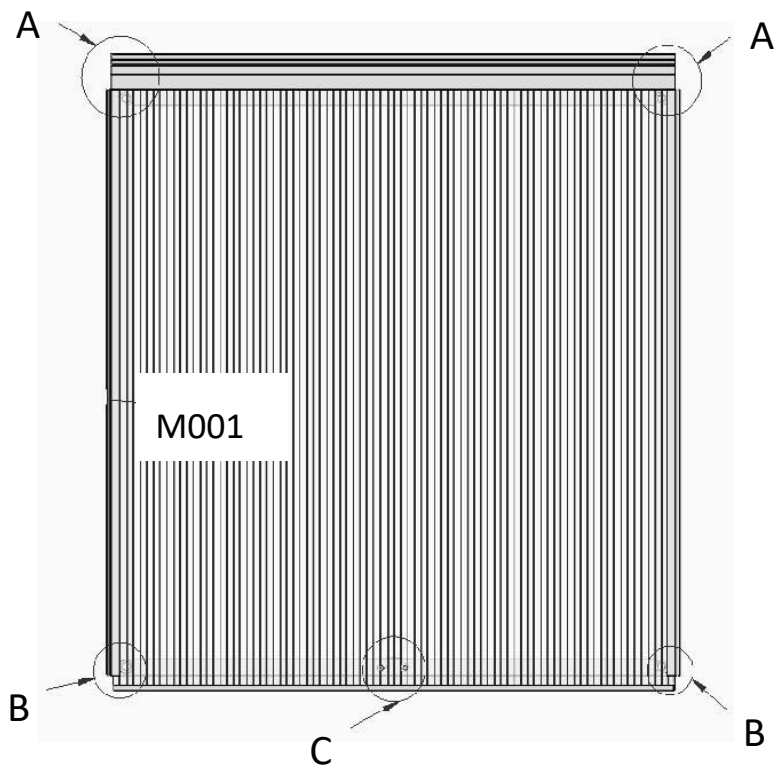
MODEL – MODEL CODE – KÓD
 LENGTH – DÉLKA QTY - MNOŽSTVÍ



MODEL	CODE	LENGTH(mm)	QTY
	C1301A	1551	1
	C1301B	1551	1
	C1801	590	1
	C701	600	1
	C1101	600	2
	C2301	600	1
	C2		4
	D6	ST4. 8X19	16
	D4	M4X10	4
	K001	562*598	2
	K002	261*598	1
	C4		10
	D1	M6X9*3.5	2
	D7	M6-GB41	2





MODEL	CODE	LENGTH(mm)	QTY
	C2401	607	2
	C2601	602	2
	C2701	600	4
	C5	332	1
	D5	ST4. 2X9. 5	4
	M001	628*604	2
	D1	M6X9*3. 5	8
	D7	M6-GB41	8

MODEL – MODEL CODE – KÓD
 LENGTH – DÉLKA QTY - MNOŽSTVÍ

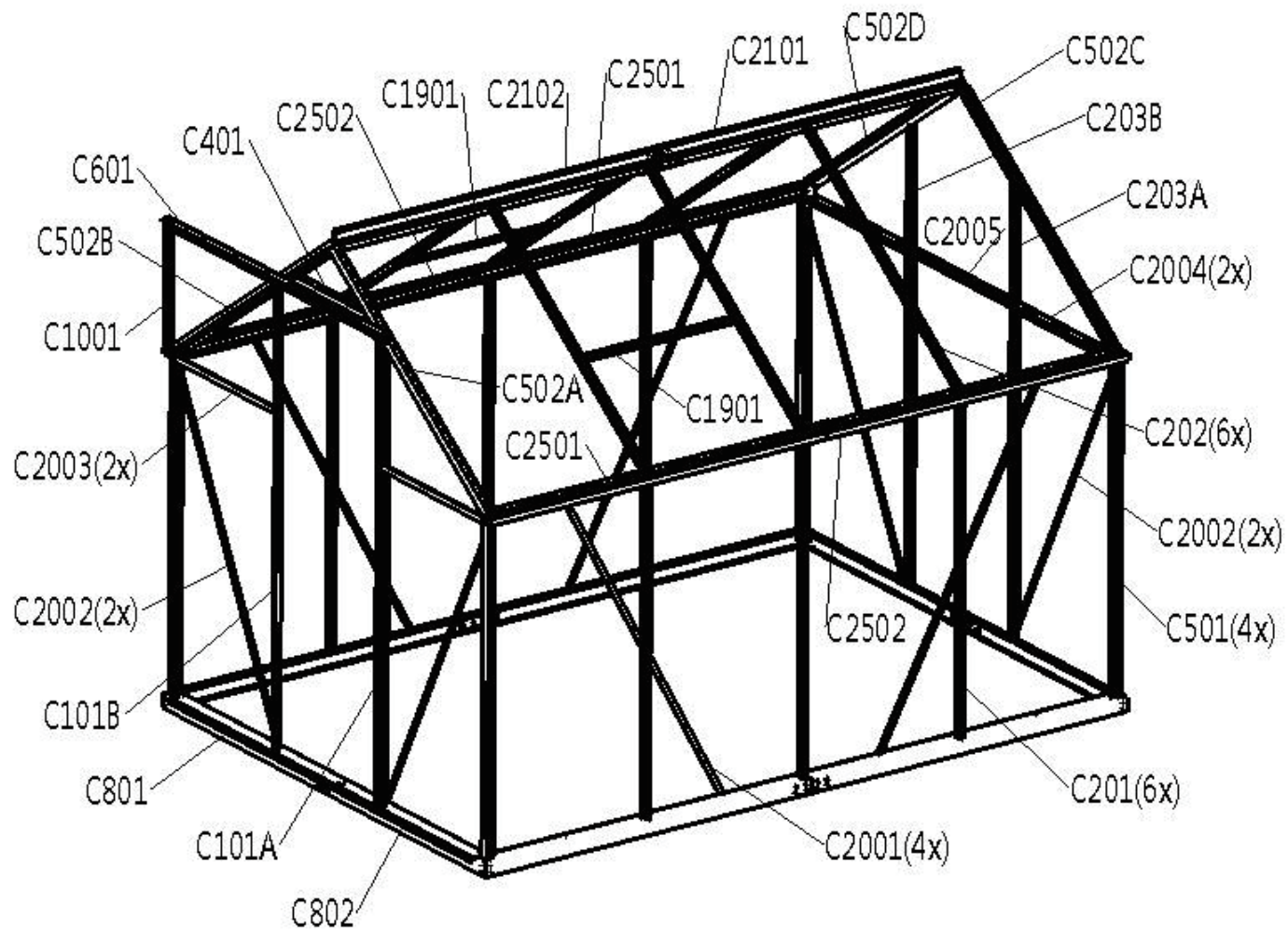

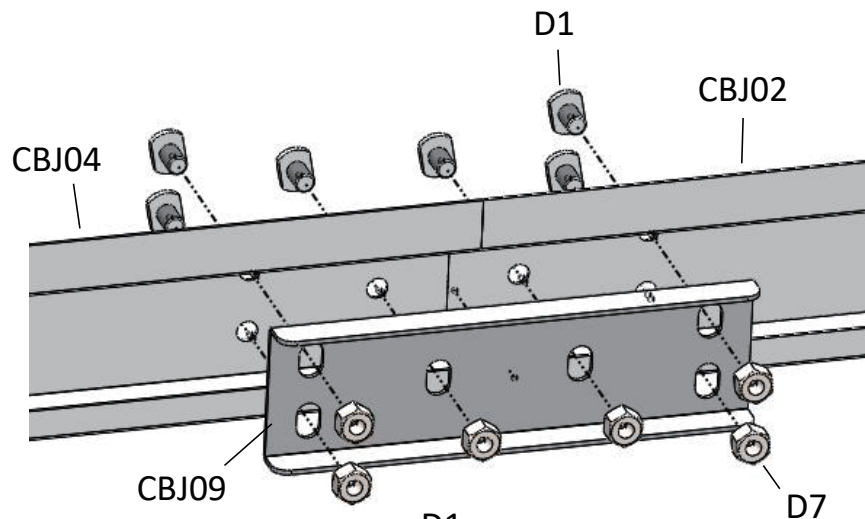



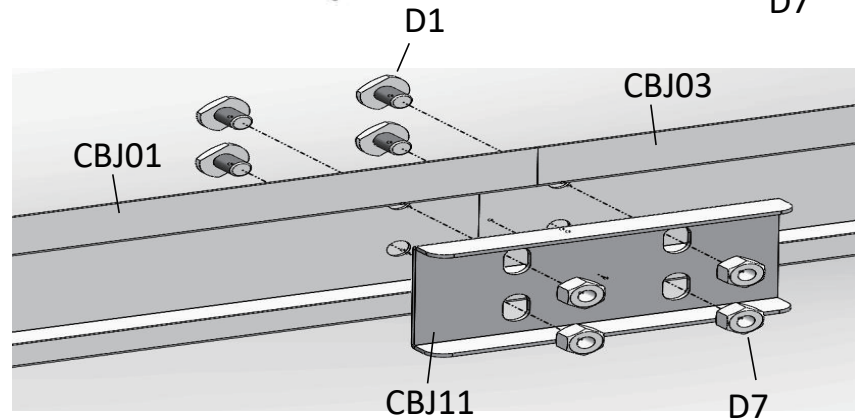



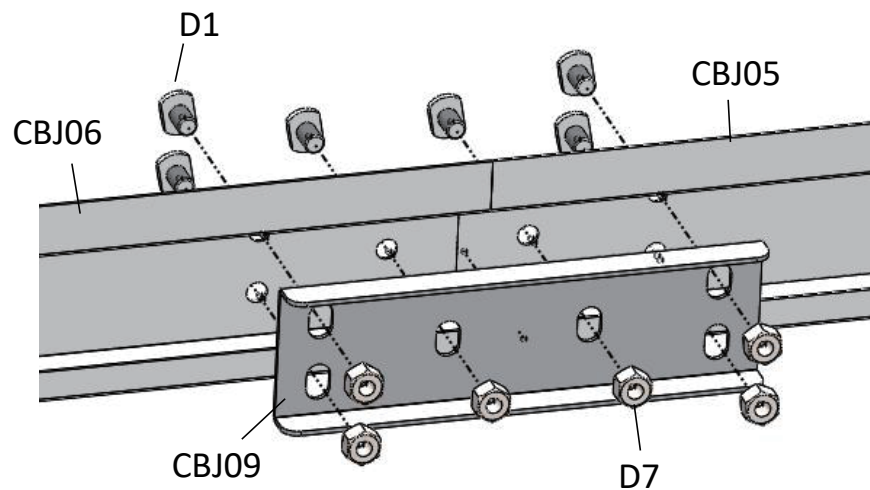



(A)



(B1)



(B2)

MODEL	CODE	LENGTH(mm)	QTY
	CBJ01	948.8	1
	CBJ03	948.8	1
	CBJ05	948.8	1
	CBJ06	948.8	1
	CBJ02	1289.6	2
	CBJ04	1249.6	2
	CBJ09	150*44	3
	CBJ11	100*44	1
	D1	M6X9*3.5	22
	D7	M6-GB41	22



MODEL – MODEL

CODE – KÓD

LENGTH – DÉLKA

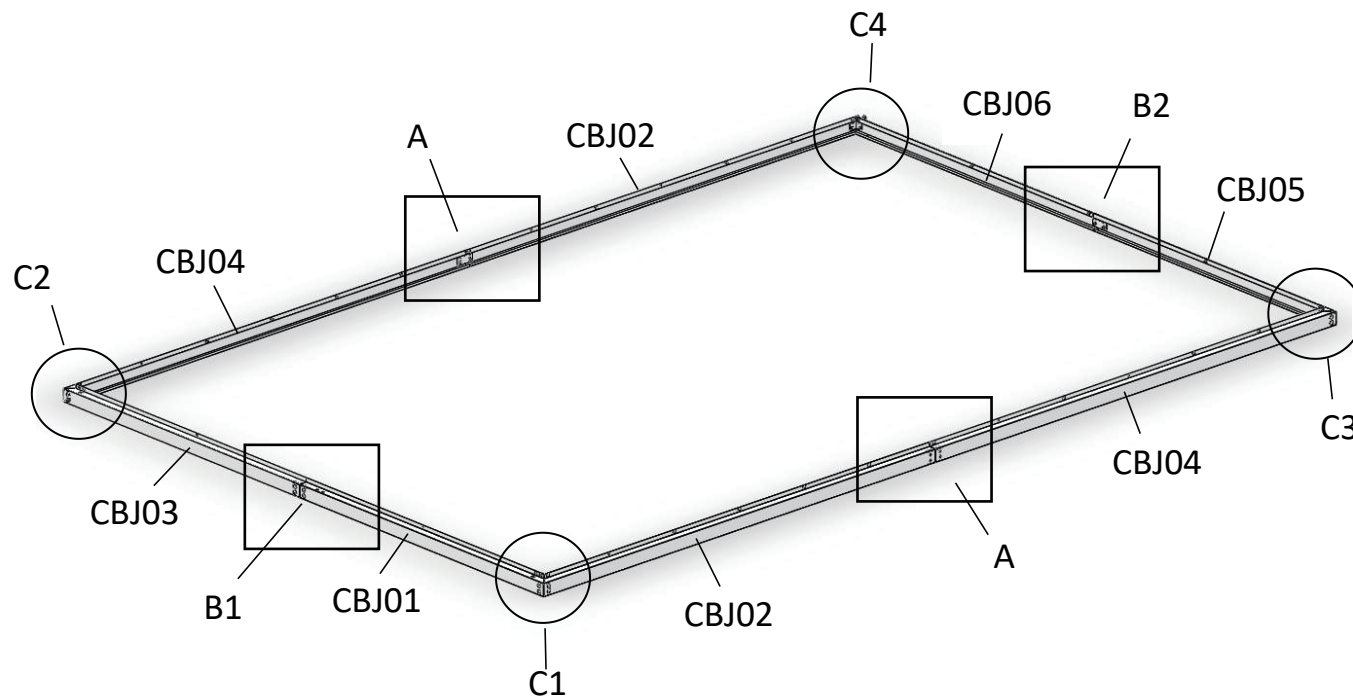
QTY - MNOŽSTVÍ



MODEL	CODE	LENGTH(mm)	QTY
	CBJ10	30*40	4
	D1	M6X9*3.5	16
	D7	M6-GB41	16

MODEL – MODEL

CODE – KÓD

LENGTH – DÉLKA

QTY – MNOŽSTVÍ

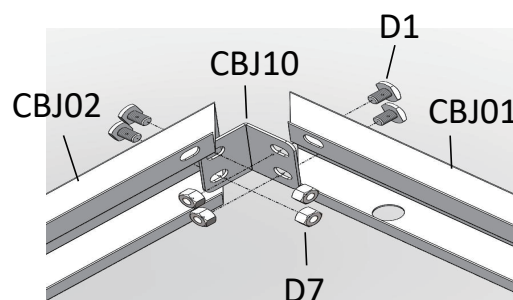

Ⓒ1

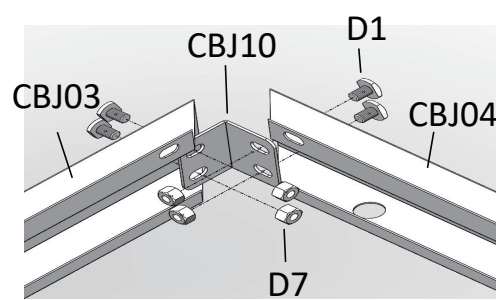

Ⓒ2

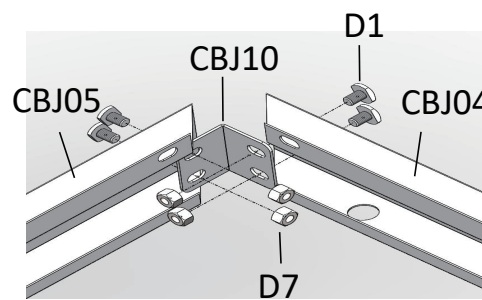

Ⓒ3

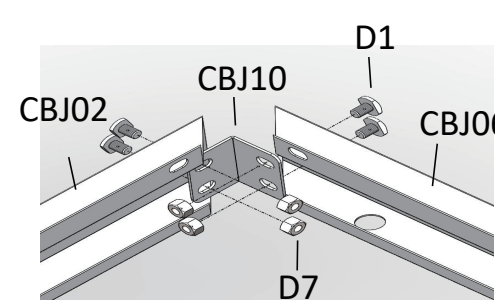

Ⓒ4



MODEL	CODE	LENGTH(mm)	QTY
	C801	971.3	1
	C802	815.9	1
	D1	M6X9*3.5	4
	D7	M6-GB41	4

MODEL – MODEL CODE – KÓD
 LENGTH – DÉLKA QTY - MNOŽSTVÍ

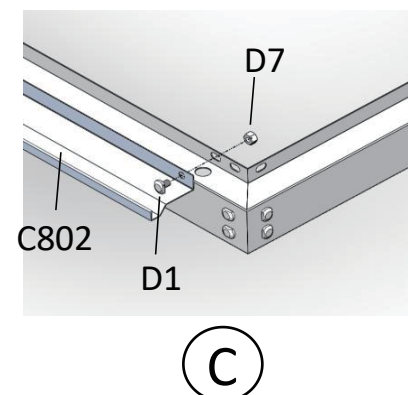
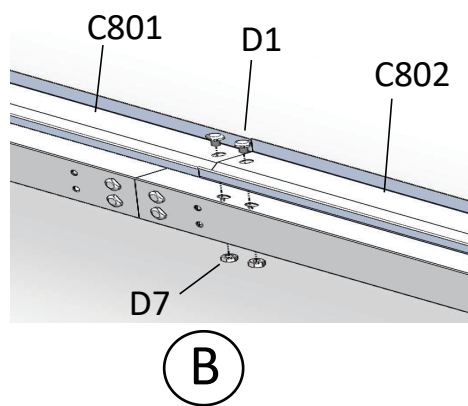
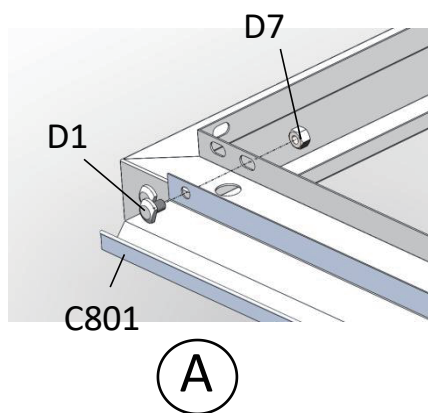

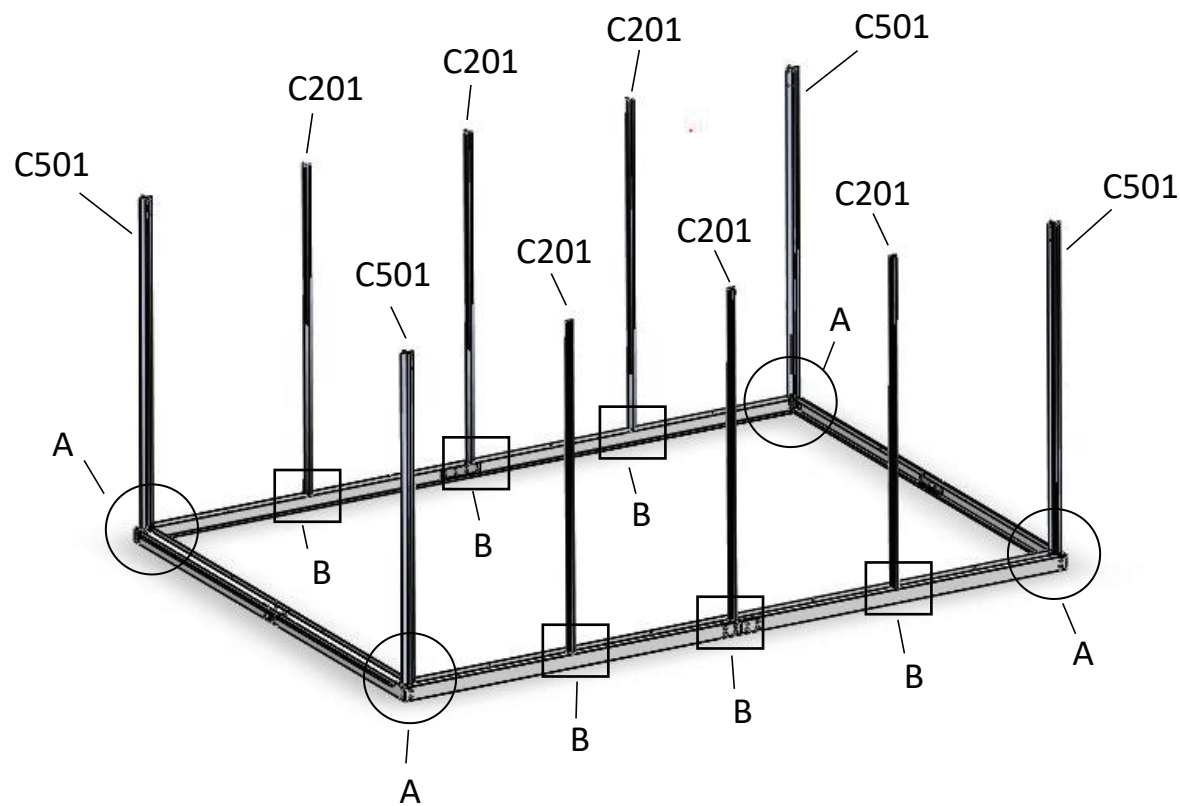

MODEL	CODE	LENGTH(mm)	QTY
	C501	1150	4
	C201	1150	6
	D1	M6X9*3.5	14
	D7	M6-GB41	14

MODEL – MODEL

CODE – KÓD

LENGTH – DÉLKA

QTY - MNOŽSTVÍ

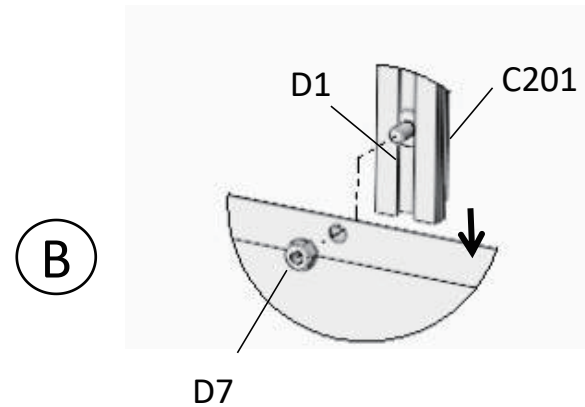
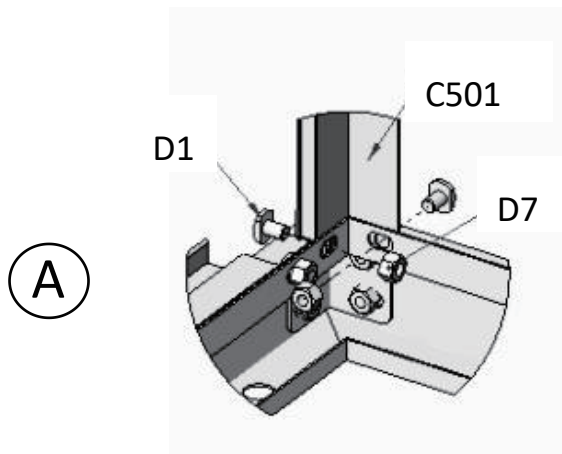

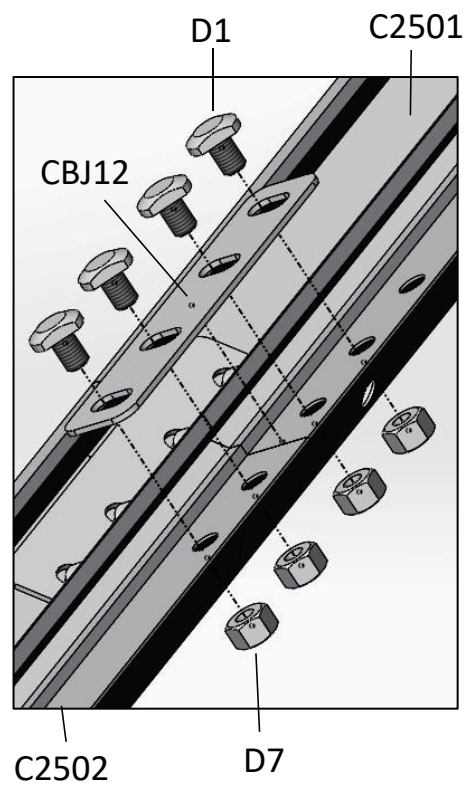
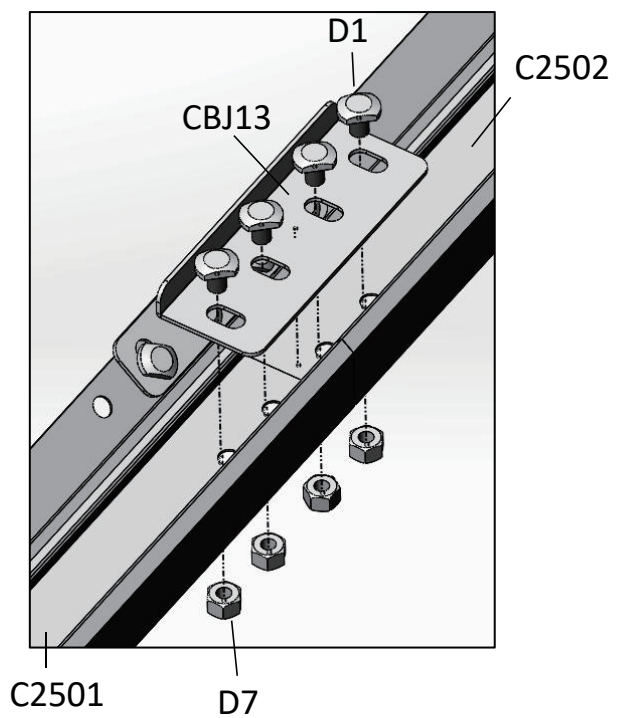
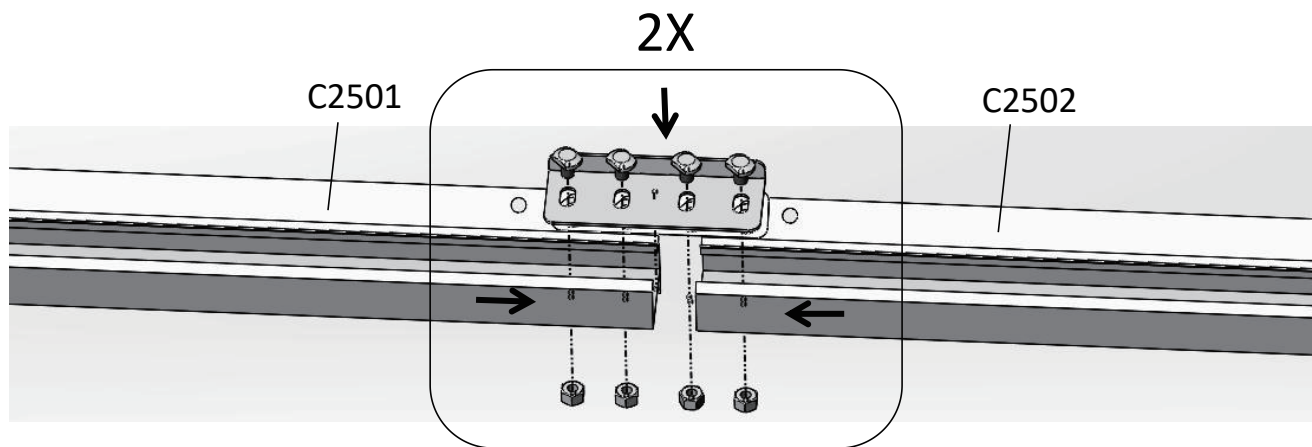

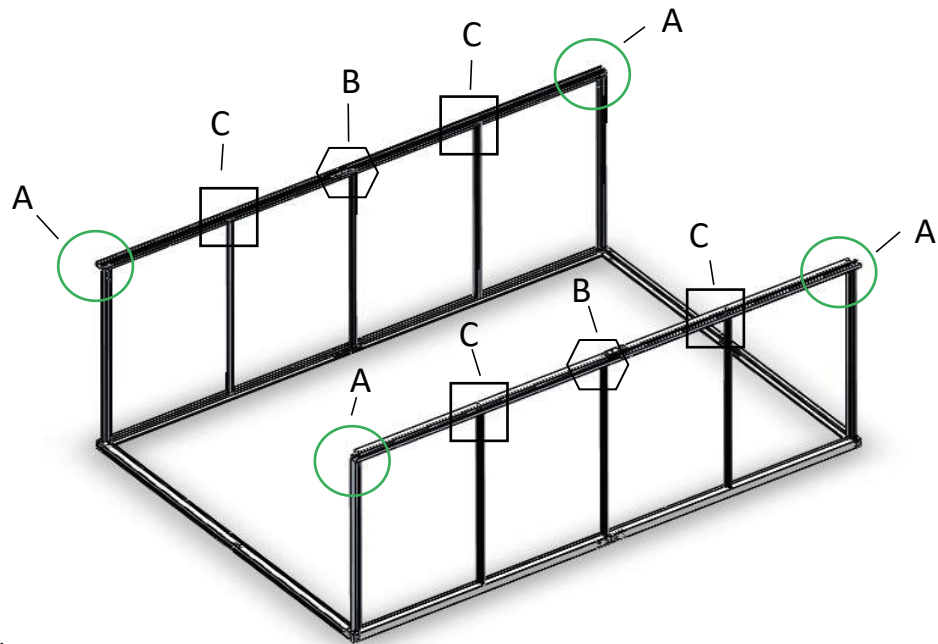

MODEL	CODE	LENGTH(mm)	QTY
	C2501	1328.5	2
	C2502	1197.7	2
	CBJ12	100*22	3
	CBJ13	100*35	2
	D7	M6-GB41	16
	D1	M6X9*3.5	16

MODEL – MODEL CODE – KÓD
 LENGTH – DÉLKA QTY - MNOŽSTVÍ



MODEL	CODE	LENGTH(mm)	QTY
	D7	M6-GB41	10
	D1	M6X9*3.5	14

MODEL – MODEL

CODE – KÓD

LENGTH – DÉLKA

QTY - MNOŽSTVÍ

A

C2501+C2502

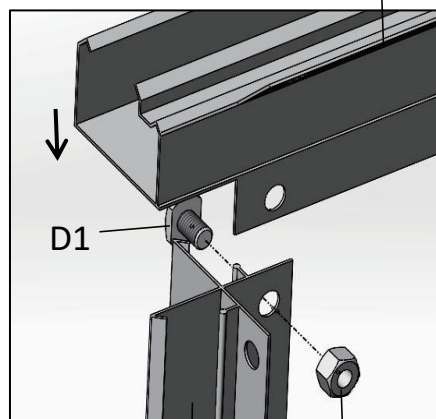

C501

D7

B

C2501+C2502

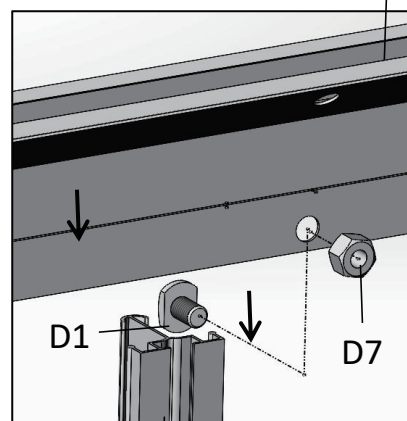

D1

D7

C201

C

C2501+C2502

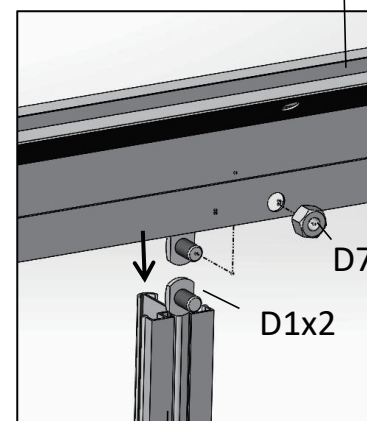



D1x2

D7

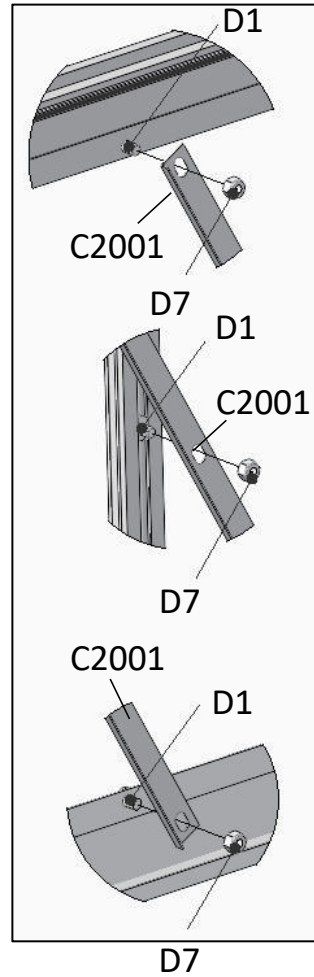
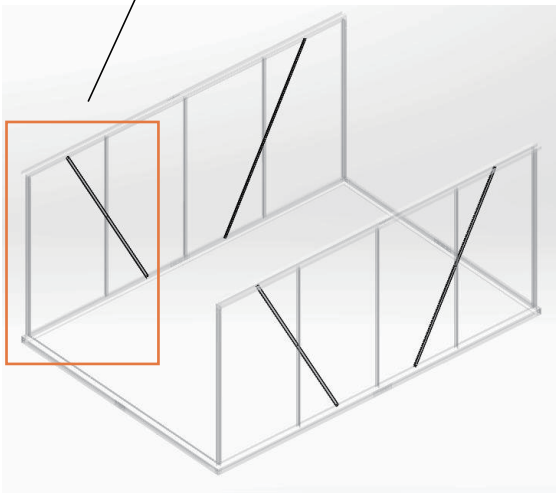
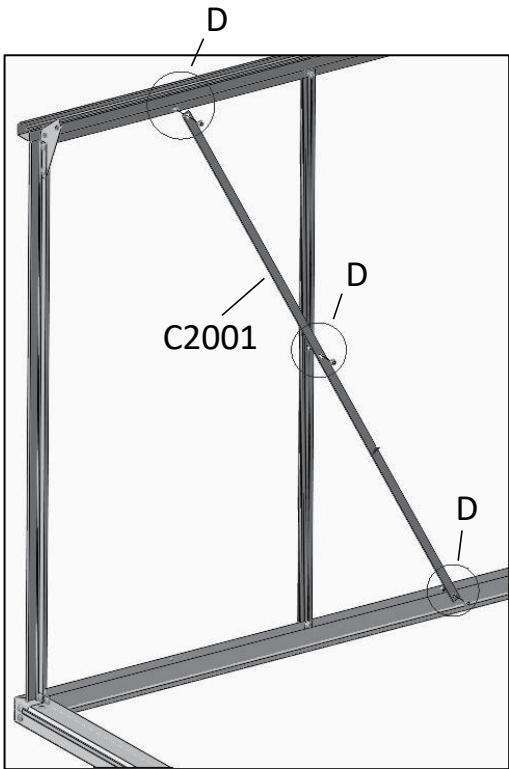
C201



(D)

MODEL	CODE	LENGTH(mm)	QTY
	C2001	1310	4
	D1	M6X9*3.5	8
	D7	M6-GB41	12





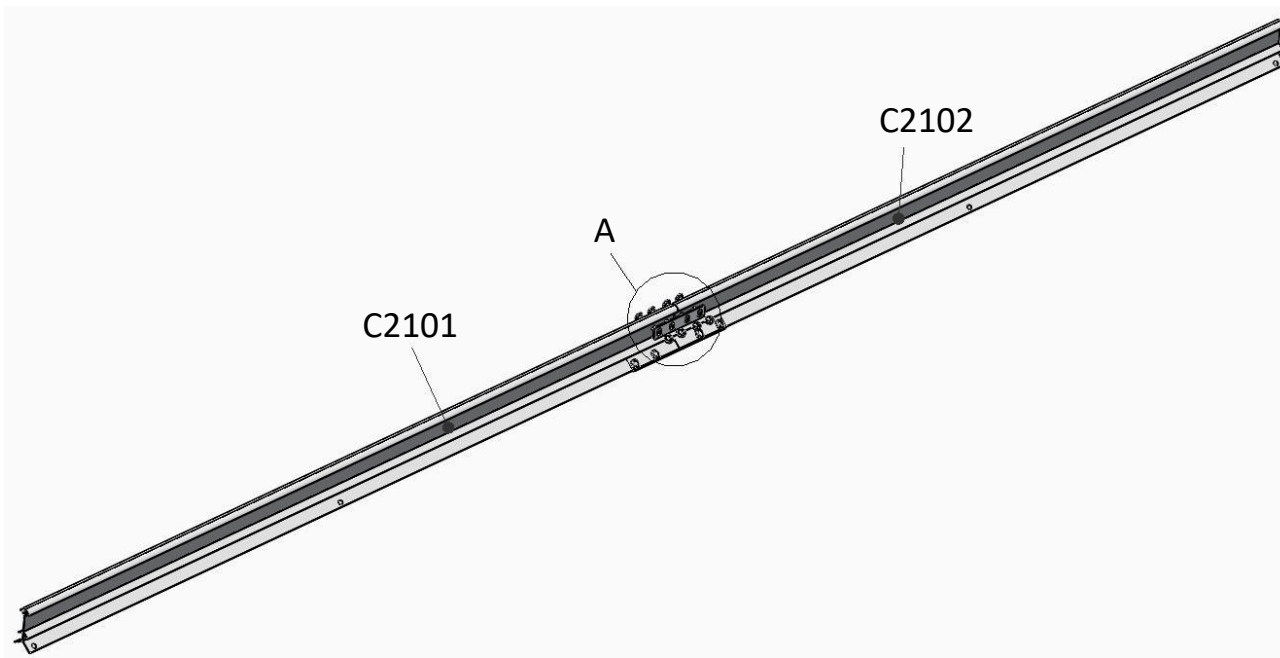

MODEL – MODEL

CODE – KÓD

LENGTH – DÉLKA

QTY - MNOŽSTVÍ



MODEL	CODE	LENGTH(mm)	QTY
	C2101	1193.7	1
	C2102	1280.5	1
	CBJ08	185	1
	CBJ12	100*22	3
	D1	M6X9*3.5	12
	D7	M6-GB41	12

MODEL – MODEL

CODE – KÓD

LENGTH – DÉLKA

QTY - MNOŽSTVÍ

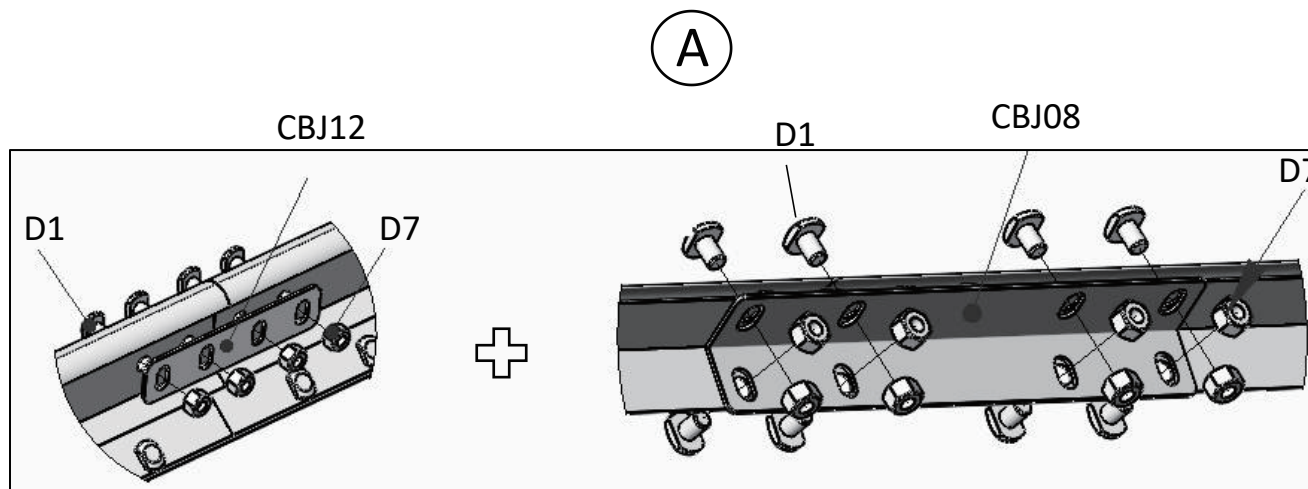

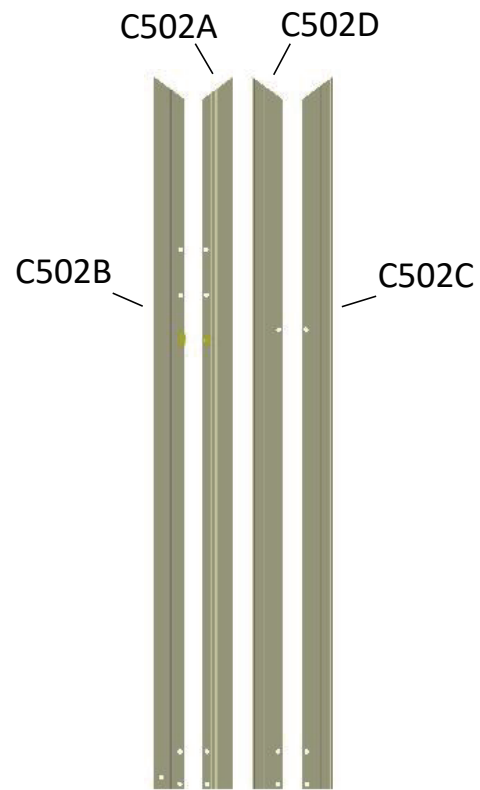
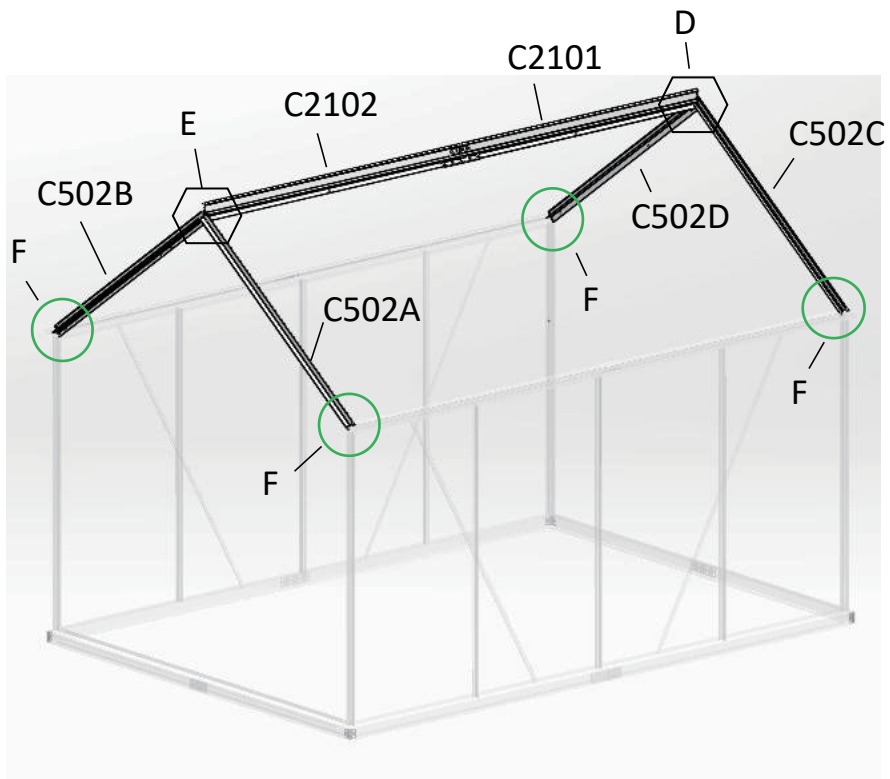

MODEL	CODE	LENGTH(mm)	QTY
	C502A	1157	1
	C502B	1157	1
	C502C	1157	1
	C502D	1157	1
	CBJ07	138*69	4
	D1	M6X9*3,5	20
	D7	M6-GB41	20

MODEL – MODEL CODE – KÓD
 LENGTH – DÉLKA QTY - MNOŽSTVÍ

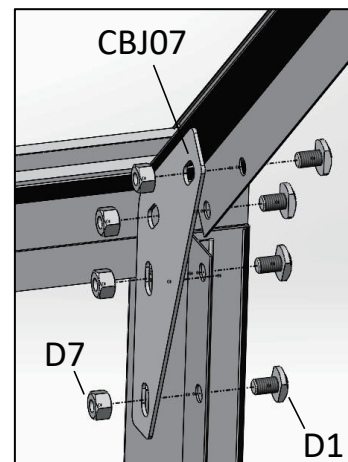
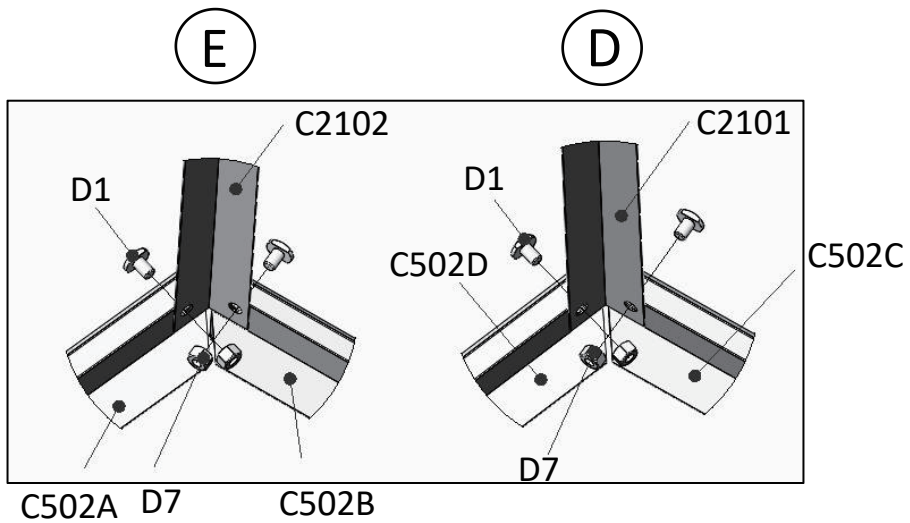

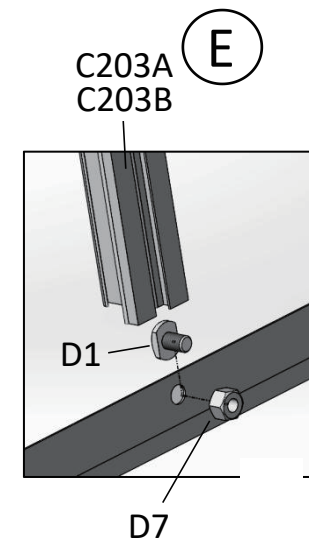
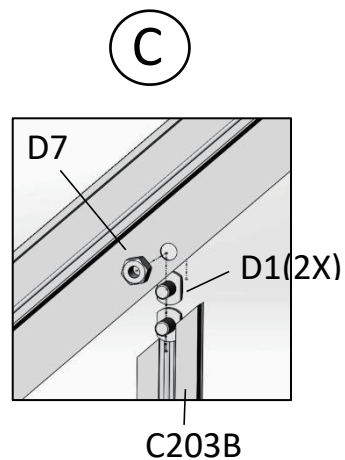
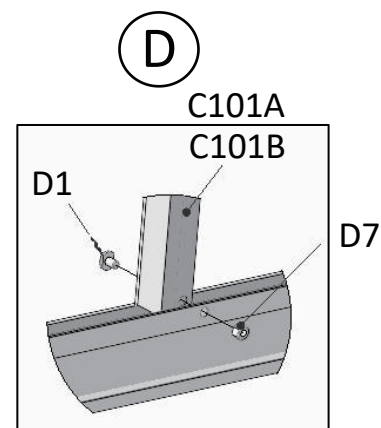
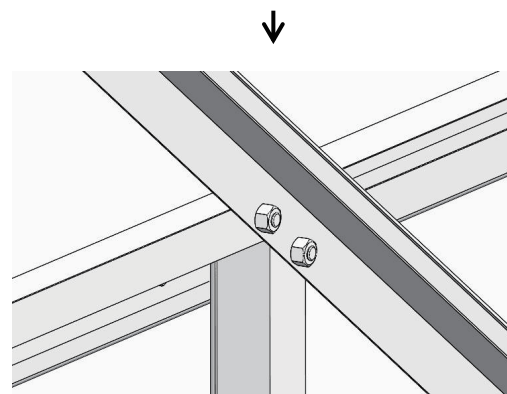
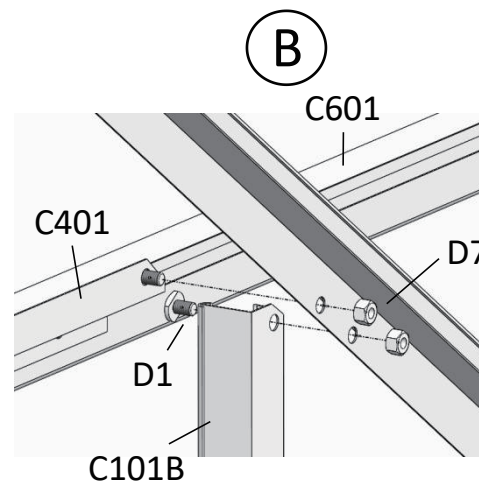
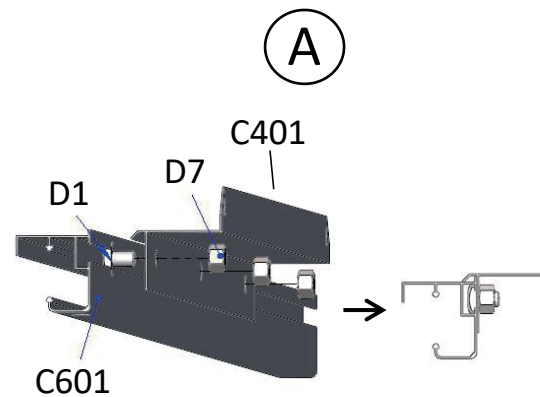
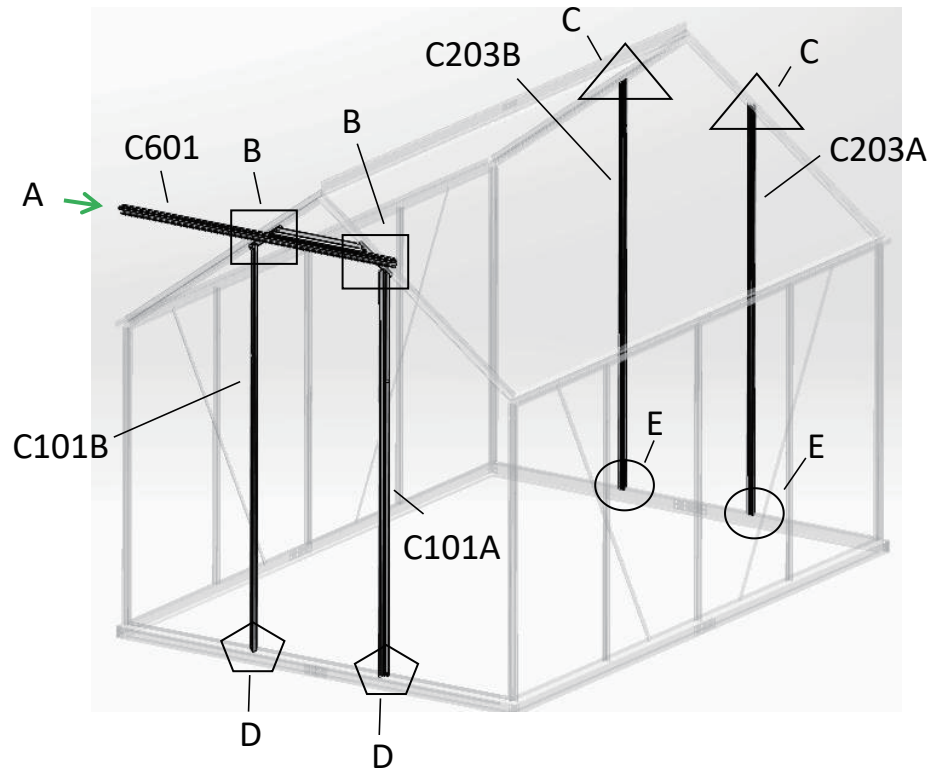

MODEL	CODE	LENGTH(mm)	QTY
	C601	1275	1
	C101A	1606	1
	C101B	1606	1
	C401	606	1
	C203A	1622	1
	C203B	1622	1
	D1	M6X9*3.5	15
	D7	M6-GB41	13

MODEL – MODEL







CODE – KÓD

LENGTH – DÉLKA

QTY - MNOŽSTVÍ

MODEL – MODEL CODE – KÓD

LENGTH – DÉLKA QTY - MNOŽSTVÍ

MODEL	CODE	LENGTH(mm)	QTY
	C2002	1253	4
	C2003	610	2
	C2004	616	2
	C2005	635	1
	D1	M6X9*3.5	2
	D7	M6-GB41	4

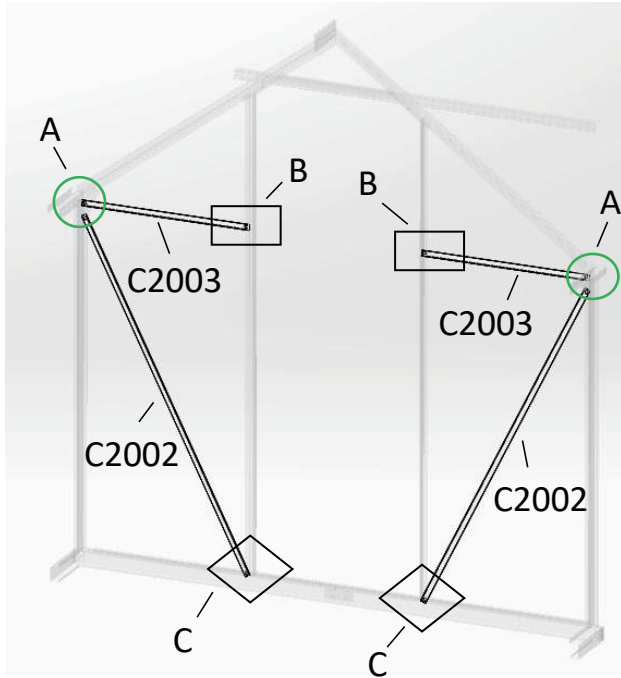

A

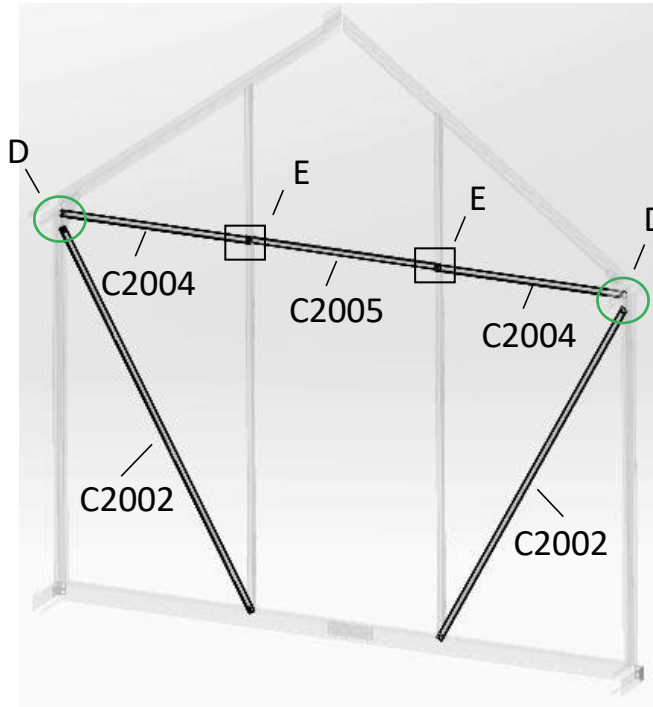

B

C

E

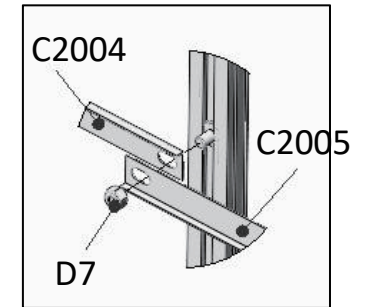

D

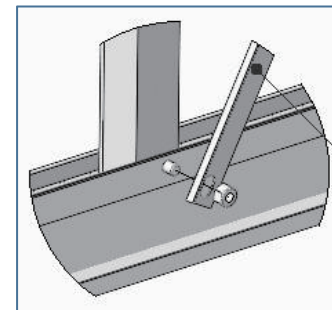
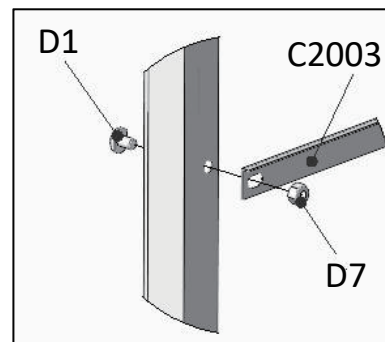
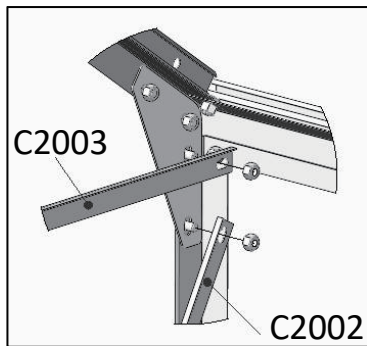

C2002

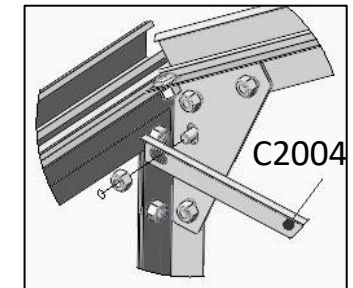

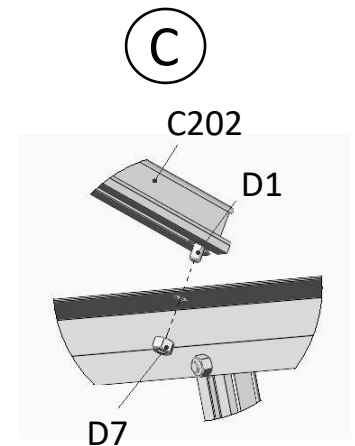
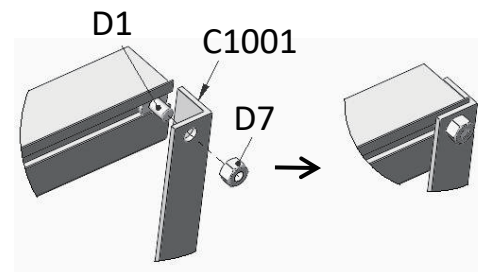
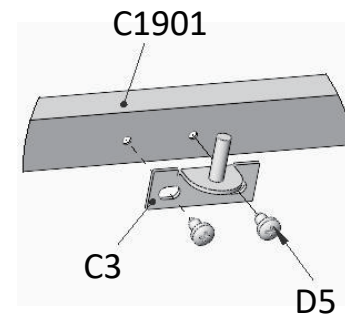
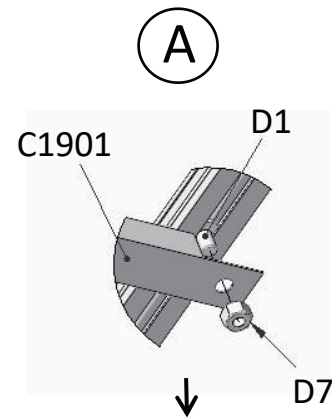
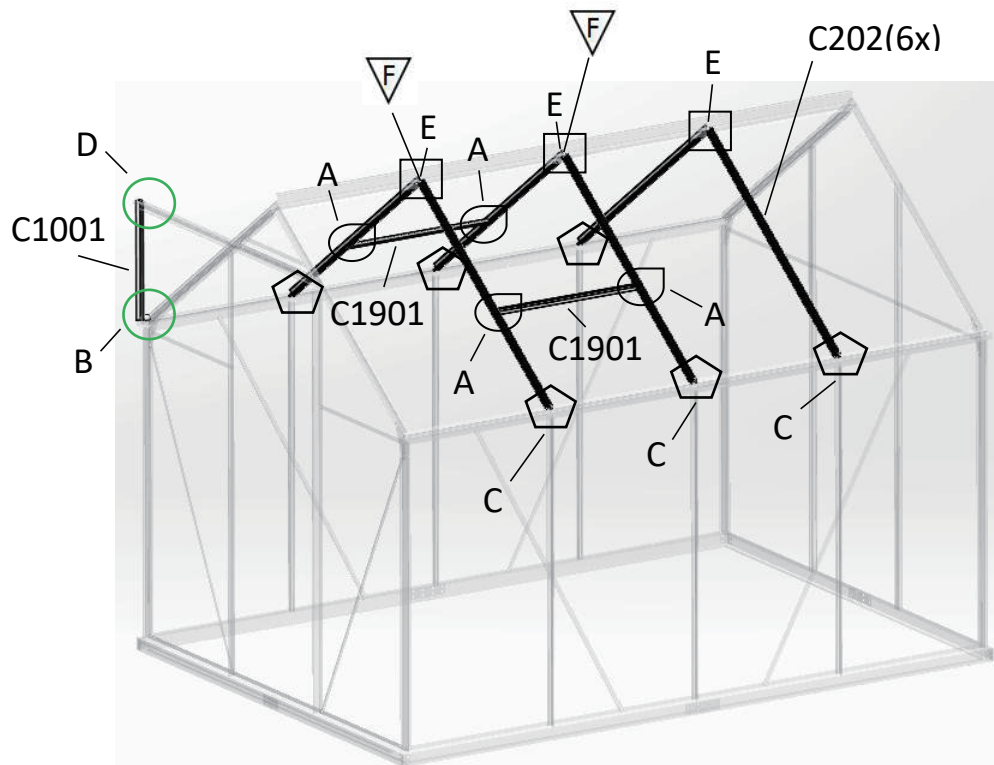

E

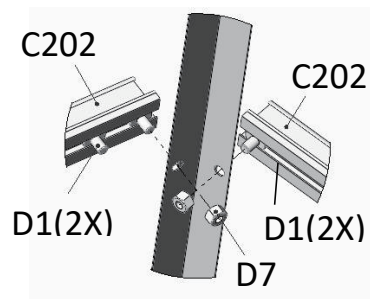

**Nejdříve proveďte montáž šroubu F:
D1 (2x)**

B

D

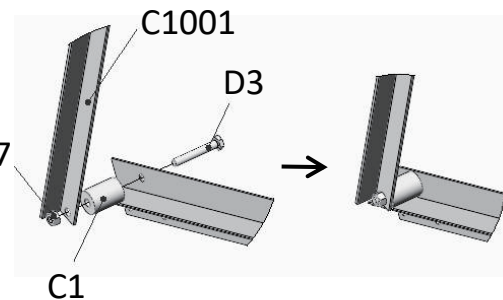

MODEL	CODE	LENGTH(mm)	QTY
	C1901	644	2
	C202	1137	6
	C1001	405.5	1
	C3		2
	C1	28	1
	D3	M6X40	1
	D5	ST4. 2X9.5	4
	D1	M6X9*3.5	17
	D7	M6-GB41	18



MODEL – MODEL

CODE – KÓD

LENGTH – DÉLKA

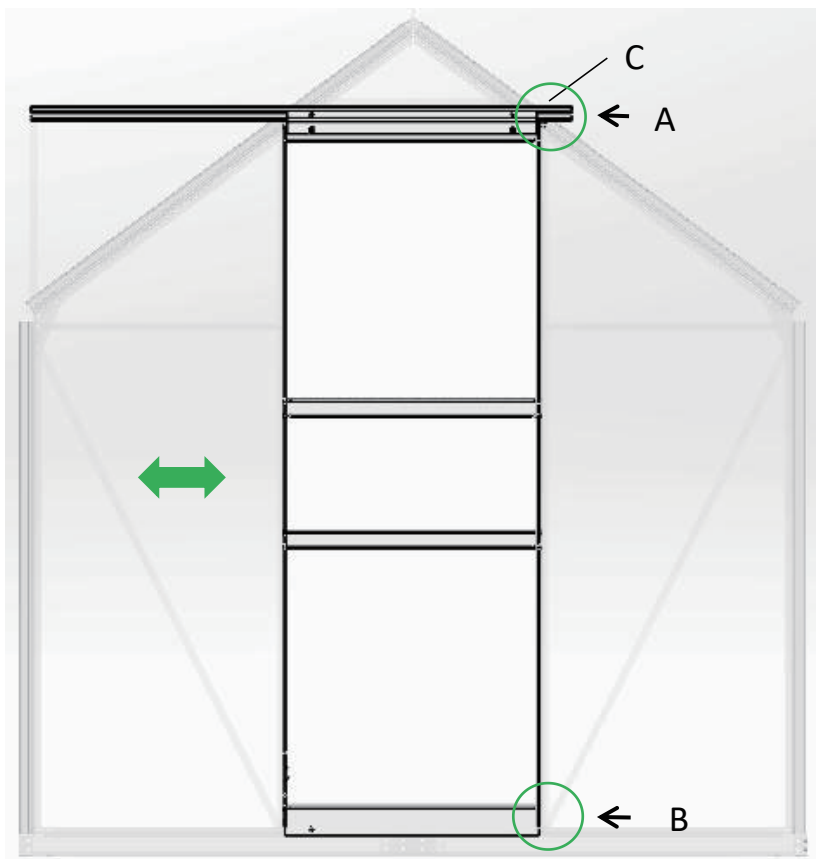
QTY - MNOŽSTVÍ



MODEL	CODE	LENGTH(mm)	QTY
	D2	M6X16	1
	D7	M6-GB41	1

MODEL – MODEL CODE – KÓD
 LENGTH – DÉLKA QTY - MNOŽSTVÍ

(A)

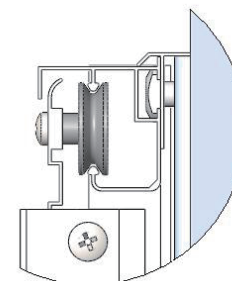

(B)

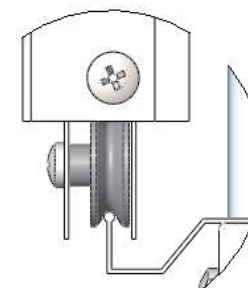

(C)

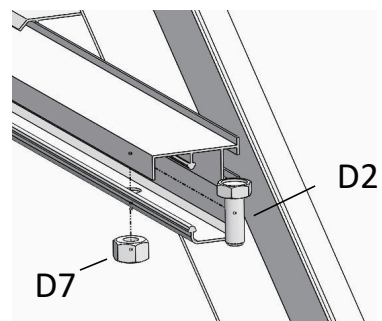

Top Beam – Horní nosník

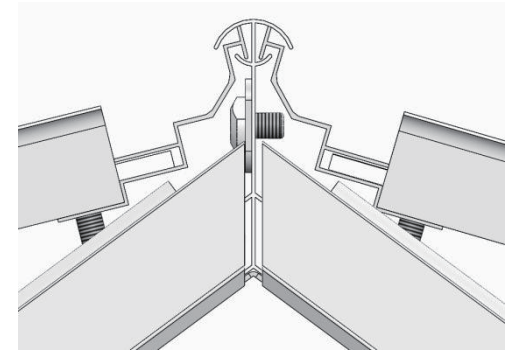
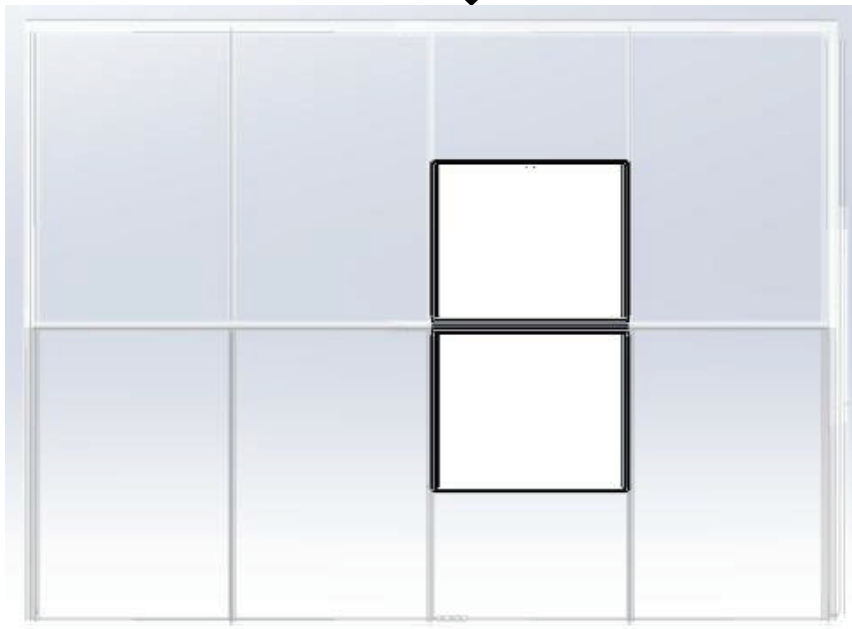
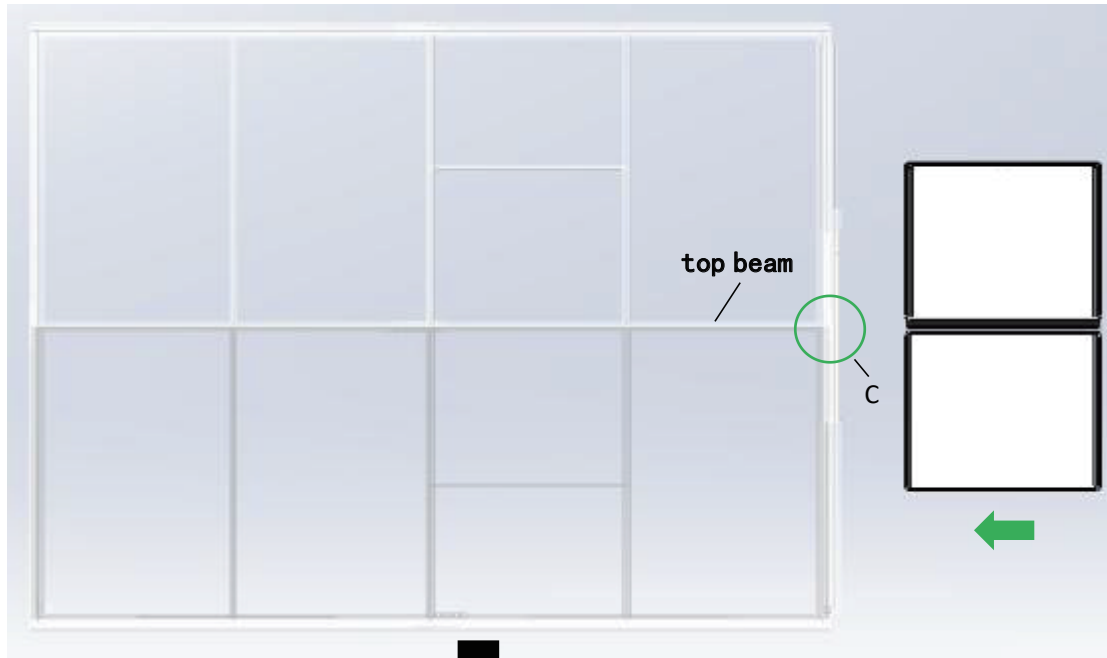

Ⓒ

ZADNÍ ČÁST

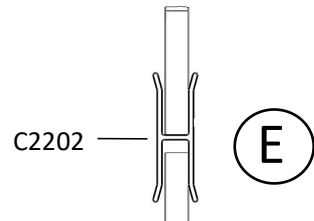

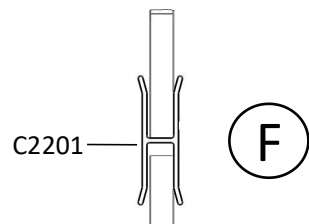
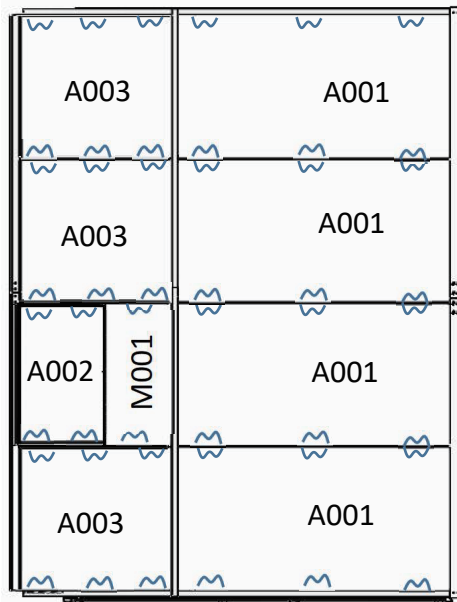

PRAVÁ STRANA

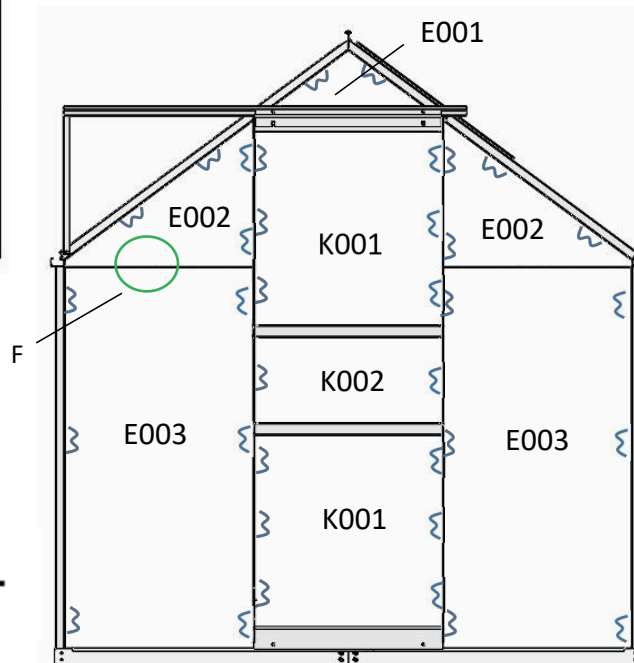
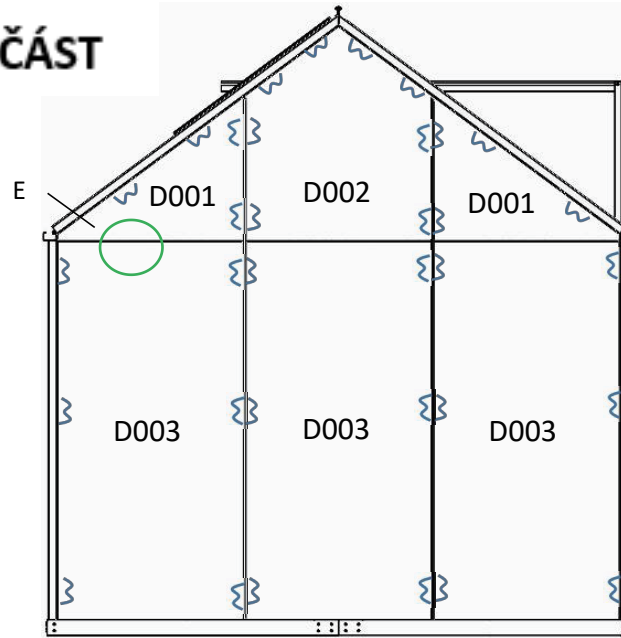

PŘEDNÍ ČÁST



MODEL	CODE	LENGTH(mm)	QTY
	C2201	621	2
	C2202	610	3
	C4		155

MODEL – MODEL CODE – KÓD

LENGTH – DÉLKA QTY - MNOŽSTVÍ

LEVÁ STRANA

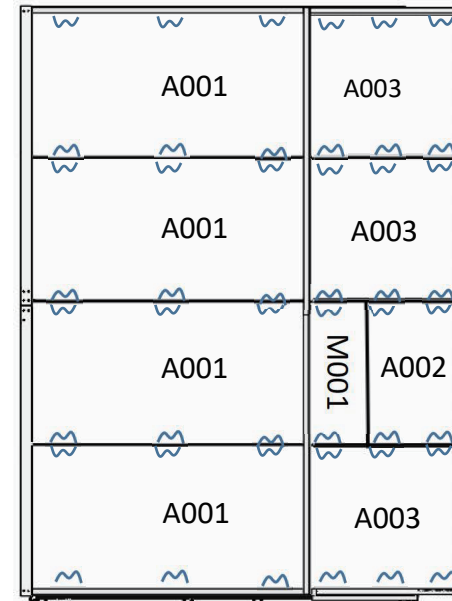

Poznámka: První deska je vložena do hliníkové části. Potom umístíte pružinu na vnější povrch proti desce ve směru instalace znázorněné na obrázku níže.

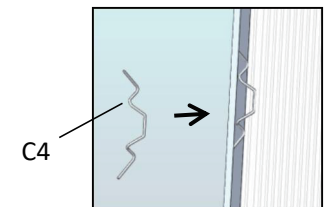

Po montáži

Pravidelně procházejte kolem skleníku a důkladně ho kontrolujte, abyste se ujistili, že všechny části jsou správně upevněny a celá konstrukce je v pořádku. Zkontrolujte všechny šrouby a matice i všechny spoje, abyste se přesvědčili, že jsou ve správné poloze.

Důrazně doporučujeme ihned odstraňovat napadaný sníh. Nenechávejte sníh ležet na střeše přes noc. Na všech stranách vždy udržujte volný prostor v šířce cca 1 metru.

Nenechte sníh hromadit po stranách skleníku. Jinak by tlak z boků tlačil směrem dovnitř a mohlo by dojít ke zhroucení skleníku.